

**669****Spezialnämaschine**

Serviceanleitung

**D**

Service Instructions

**GB**

*Alle Rechte vorbehalten.*

Eigentum der Dürkopp Adler AG und urheberrechtlich geschützt. Jede, auch auszugsweise Wiederverwendung dieser Inhalte ist ohne vorheriges schriftliches Einverständnis der Dürkopp Adler AG verboten.

*All rights reserved.*

Property of Dürkopp Adler AG and copyrighted. Reproduction or publication of the content in any manner, even in extracts, without prior written permission of Dürkopp Adler AG, is prohibited.

**Copyright © Dürkopp Adler AG - 2009**

## General safety instructions

**The non-observance of the following safety instructions can cause bodily injuries or damages to the machine.**

1. The machine must only be commissioned in full knowledge of the instruction book and operated by persons with appropriate training.
2. Before putting into service also read the safety rules and instructions of the motor supplier.
3. The machine must be used only for the purpose intended. Use of the machine without the safety devices is not permitted. Observe all the relevant safety regulations.
4. When gauge parts are exchanged (e.g. needle, presser foot, needle plate, feed dog and bobbin) when threading, when the workplace is left, and during service work, the machine must be disconnected from the mains by switching off the master switch or disconnecting the mains plug.
5. Daily servicing work must be carried out only by appropriately trained persons.
6. Repairs, conversion and special maintenance work must only be carried out by technicians or persons with appropriate training.
7. For service or repair work on pneumatic systems, disconnect the machine from the compressed air supply system (max. 7-10 bar). Before disconnecting, reduce the pressure of the maintenance unit. Exceptions to this are only adjustments and functions checks made by appropriately trained technicians.
8. Work on the electrical equipment must be carried out only by electricians or appropriately trained persons.
9. Work on parts and systems under electric current is not permitted, except as specified in regulations DIN VDE 0105.
10. Conversion or changes to the machine must be authorized by us and made only in adherence to all safety regulations.
11. For repairs, only replacement parts approved by us must be used.
12. Commissioning of the sewing head is prohibited until such time as the entire sewing unit is found to comply with EC directives.
13. The line cord should be equipped with a country-specific mains plug. This work must be carried out by appropriately trained technicians (see paragraph 8).



It is absolutely necessary to respect the safety instructions marked by these signs.

**Danger of bodily injuries !**

Please note also the general safety instructions.





## Service Instructions Class 669

(Edition 09/2009)

<b>1.</b>	<b>General</b>	
1.1	Gauges. . . . .	3
1.2	Description of the setting positions . . . . .	4
<b>2.</b>	<b>Sewing machine</b>	
2.1	Position of the arm shaft crank on the arm shaft . . . . .	5
2.2	Upper and lower toothed belt wheel / toothed belt . . . . .	6
2.2.1	Position of the upper toothed belt wheel . . . . .	6
2.2.2	Position of the lower toothed belt wheel . . . . .	7
2.3	Bottom feed and stitch regulator gear . . . . .	8
2.3.1	Basic setting of stitch adjustment . . . . .	8
2.3.2	Adjust the 2nd stitch length . . . . .	10
2.3.3	Position of the feed dog in the throat plate cutout . . . . .	11
2.3.4	Feeding motion of the feed dog . . . . .	12
2.3.5	Lifting motion of the feed dog . . . . .	13
2.3.6	Feed dog height . . . . .	14
2.3.7	Neutralizing the feed dog stroke. . . . .	15
2.4	Transmission lever. . . . .	16
2.5	Needle bar linkage . . . . .	17
2.5.1	Align the needle bar linkage laterally . . . . .	17
2.5.2	Needle penetration in feeding direction . . . . .	18
2.6	Hook, looping stroke and needle bar height. . . . .	19
2.6.1	Looping stroke, distance between the hook point and needle . . . . .	19
2.6.2	Needle bar height . . . . .	21
2.7	Throat plate base . . . . .	22
2.8	Feeding foot and presser foot . . . . .	23
2.8.1	Feeding foot and presser foot stroke . . . . .	23
2.8.2	Stroke motion of the feeding foot . . . . .	24
2.8.3	Sewing foot pressure . . . . .	25
2.9	Stitch length limitation. . . . .	26
2.10	Stitch equality of the forward and backward stitch . . . . .	27
2.11	Sewing foot lifting . . . . .	28
2.11.1	Mechanical sewing foot lifting . . . . .	28
2.11.2	Height of the sewing feet arrested with hand lever. . . . .	29
2.11.3	Height of the lifted sewing feet. . . . .	30
2.12	Thread-guiding parts . . . . .	31
2.12.1	Thread regulator . . . . .	31
2.12.2	Thread take-up spring. . . . .	32
2.13	Bobbin winder. . . . .	34
2.14	Thread trimmer . . . . .	37
2.14.1	Mechanical part . . . . .	37

2.14.2	Thread trimmer cam position . . . . .	38
2.14.3	Play between the roller and the control cam . . . . .	39
2.14.4	Setting the cutting pressure . . . . .	40
2.15	Potentiometer in the arm . . . . .	41
2.15.1	Basic setting without control panel . . . . .	41
2.15.2	Basic setting with the control panel V810 or V820 . . . . .	42
2.15.3	Check the potentiometer adjustment . . . . .	43
2.16	Connections PCB . . . . .	44
<b>3.</b>	<b>Oil lubrication</b>	
3.1	Hook lubrication . . . . .	46
<b>4.</b>	<b>Maintenance</b> . . . . .	47

## 1. General

The present service instruction describes the adjustment of the special sewing machine 669.



### ATTENTION!

The operations described in the service instructions must only be executed by qualified staff or correspondingly instructed persons respectively!



### Caution: Risk of injury!

In case of repair, alteration or maintenance work turn off the main switch and make sure to disconnect the machine from the air supply system.

Carry out adjusting operations and functional tests of the running machine only under observation of all safety measures and with utmost caution.

The present service instruction describes the adjustment of the sewing machine in an appropriate sequence. Please observe in this connection that various setting positions are interdependent. Therefore it is absolutely necessary to perform the adjustment following the described order.

For all setting operations of parts involved in the stitch formation use a new needle without any damage.

Machine covers having to be screwed off and on again for checking and adjusting operations are not mentioned in the text.

### Please note:

Some shafts of the special sewing machine 669 are provided with flat spots. This facilitates the adjustment considerably.

In case of adjustments on flat spots the first screw in rotation direction is put on such a flat spot.

GB

### 1.1 Gauges



The locking pin 1 required for adjusting the machine belongs to the serial equipment of the machine. It is in the accessories of the machine.

## 1.2 Description of the setting positions

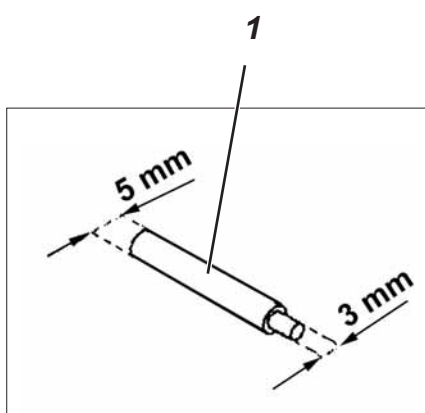
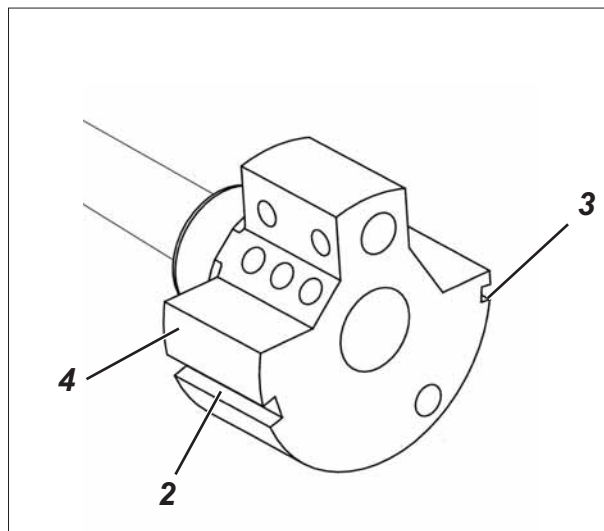

The sewing machine can be locked in 2 different setting positions with the locking pin 1 and the arresting notches 2 and 3 on the arm shaft crank 4.

Position I = Locking pin  $\varnothing$  5 mm for large groove  
= Looping stroke, needle bar height

Position II = Locking pin  $\varnothing$  3 mm for small groove  
= Needle bar at its upper dead center

## 2. Sewing machine

### 2.1 Position of the arm shaft crank on the arm shaft

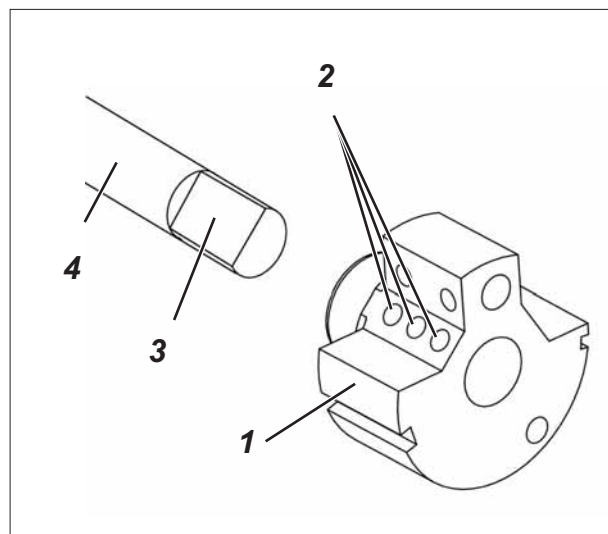
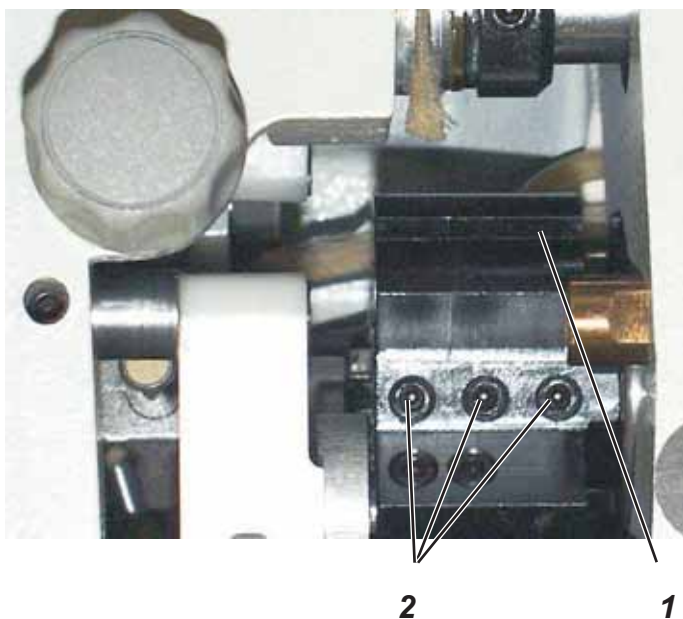

#### **Caution: Risk of injury!**

Turn off the main switch.

Check and set the position of the arm shaft crank only with the sewing machine switched off.

#### **Standard checking**

The arm shaft crank 1 is fastened on the arm shaft 4 with the three screws 2.

The screws must sit on the flat spot 3.

#### **Correction**

- Loosen screws 2 at the arm shaft crank.
- Twist arm shaft crank on the shaft in such a way that the screws 2 sit on the flat spot 3.
- Push arm shaft crank axially to the right as far as it will go.
- Tighten screws 2.

## 2.2 Upper and lower toothed belt wheel / toothed belt

### 2.2.1 Position of the upper toothed belt wheel

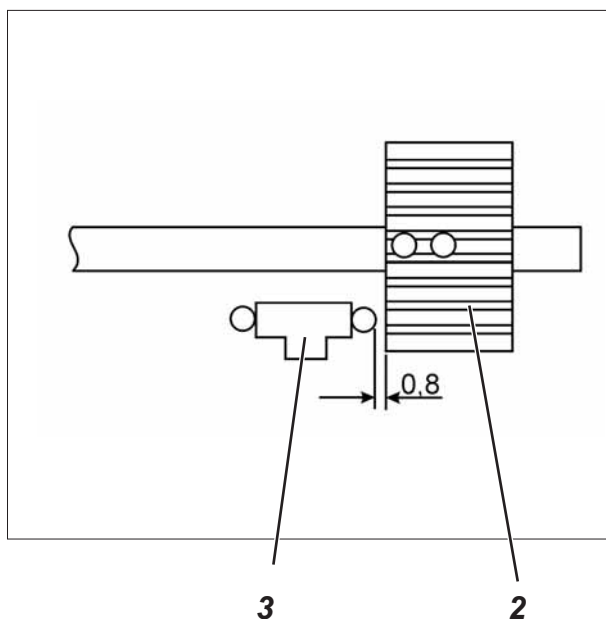
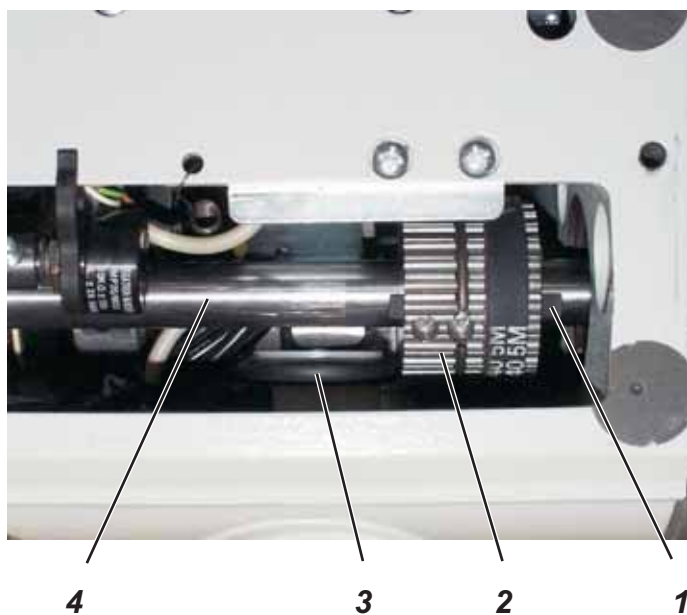

#### **Caution: Risk of injury!**

Turn off the main switch.

Check and set the position of the upper toothed belt wheel only with the sewing machine switched off.

#### **Standard checking**

The toothed belt wheel 2 is fastened on the arm shaft 4 with two threaded pins. The screws must sit on the flat spot 1.

The distance between the toothed belt wheel 2 and the bobbin winder wheel 3 must amount to 0.8 mm when the bobbin winder is switched off.

- Check distance between toothed belt wheel 2 and bobbin winder wheel 3 by means of a feeler gauge.

#### **Correction**

- Loosen the threaded pins in the toothed belt wheel.
- Turn the toothed belt wheel, until the threaded pins sit on the flat spot 1 of the arm shaft 4.
- Set lateral distance of 0.8 mm between toothed belt wheel 2 and bobbin winder wheel 3 using the feeler gauge.
- Tighten the threaded pins in the toothed belt wheel.

## 2.2.2 Position of the lower toothed belt wheel

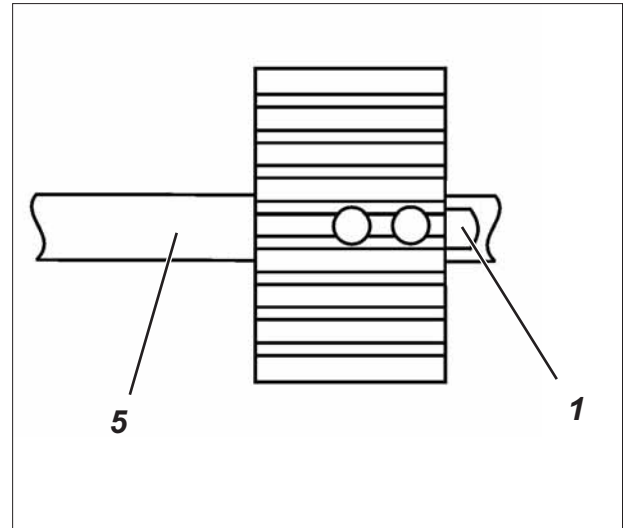
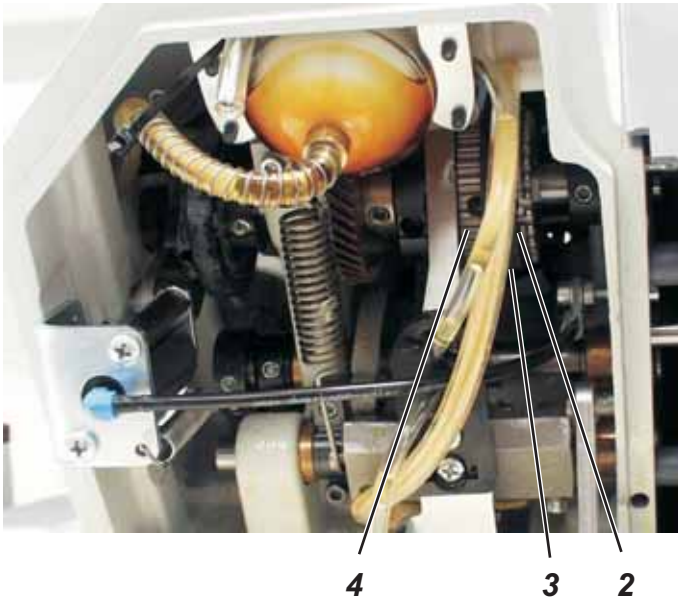

### Caution: Risk of injury!

Turn off the main switch.

Check and set the position of the lower toothed belt wheel only with the sewing machine switched off.

GB

### Standard checking

The screws in the toothed belt wheel 4 must sit on the flat spot 1 of the lower shaft 5.

The toothed belt wheel must be positioned in a way that when turning the handwheel the toothed belt 3 bears against the belt tensioner ring 2 without being dislocated.

- Check the position of the toothed belt wheel.

### Correction

- Pull out the toothed belt from the lower toothed belt wheel.
- Loosen the threaded pins in the toothed belt wheel.
- Turn the toothed belt wheel 4, until the screws sit on the flat spot of the arm shaft 5.
- Tighten the threaded pins in the toothed belt wheel.
- Put the toothed belt on the toothed belt wheel again.
- Check the course of the toothed belt.



### Attention Danger of Breakage!

After replacing the toothed belt, check the following: Hook adjustment (see chapter 2.6), feeding motion of the feed dog (see chapter 2.3.4) and lifting motion of the feed dog (see chapter 2.3.5).

## 2.3 Bottom feed and stitch regulator gear

### 2.3.1 Basic setting of stitch adjustment



2

1



6

5

4

3



#### Caution: Risk of injury!

Turn off the main switch.

Set the basic setting of stitch adjustment only with the sewing machine switched off.

#### Standard checking

When the setting wheel 5 is in "0" position, the stitch regulator gear should have the least possible play.

- Set stitch length "0" at the setting wheel 5.
- Check the play of the stitch regulator gear at the stitch regulator lever 2.



7

#### Correction

- Unclamp the spring 1.
- Retain the setting wheel 5 using the wrench 3.
- Unscrew the screw 4 and remove the setting wheel 5.
- Turn shaft 7 to the right using a 10 mm open-end wrench until the stitch regulator lever 1 has the least possible play.



#### Attention Danger of Breakage!

Do not turn the shaft too far to the right. The stitch regulator parts may jam and the maximum stitch length of 9 mm and 6 mm can respectively no longer be achieved.

- Set scale 6 to "0".
- Put setting wheel 5 on again and tighten it with screw 4.
- Put the spring 1 again.
- Check the clearance of the stitch regulator lever 2.



2

1

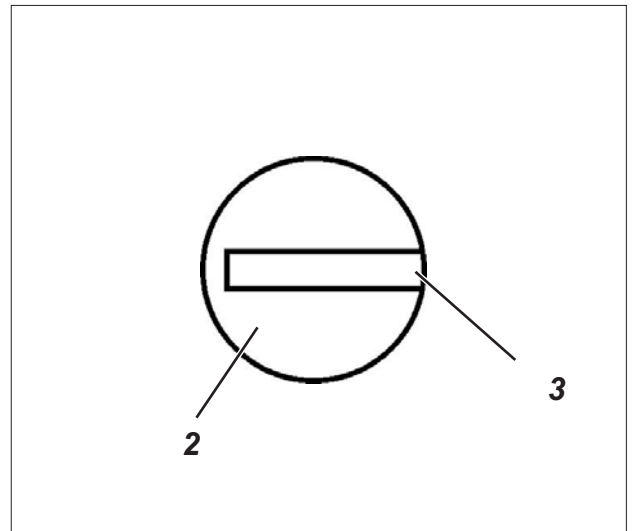

2

3

### Adjust eccentric

The eccentric 2 has to be adjusted in such a way that the open side 3 of the eccentric slot superimposes the screw 1.

- Loosen the screw 1.
- Turn the eccentric 2 in such a way that the open side 3 of the eccentric slot be oriented to the screw 1.
- Fasten the screw 1.

GB

### 2.3.2 Adjust the 2nd stitch length



4 3 2 1



4 5



#### **Caution: Risk of injury!**

Turn off the main switch.

Set the basic setting of stitch adjustment only with the sewing machine switched off.

- Set the upper setting wheel 1 to "4".
- Unscrew the screw 2 and remove the setting wheel 3.
- Using a 10 mm open-end wrench, turn with caution the shaft 5 clockwise as far as it will go.
- Set scale 4 to "4".
- Put setting wheel 3 on again and tighten it with screw 2.

### 2.3.3 Position of the feed dog in the throat plate cutout



2

1



4

3



#### **Caution: Risk of injury!**

Turn off the main switch.

Set and check the feed dog only with the sewing machine switched off.

GB

#### **Standard checking**

The feed dog 1 should be positioned so that the distance to the right and left edge of the throat plate cutout 2 is identical.

#### **Correction**

- Loosen screw 3.
- Shift laterally the plate 4 correspondingly.
- Tighten screw 3.

### 2.3.4 Feeding motion of the feed dog

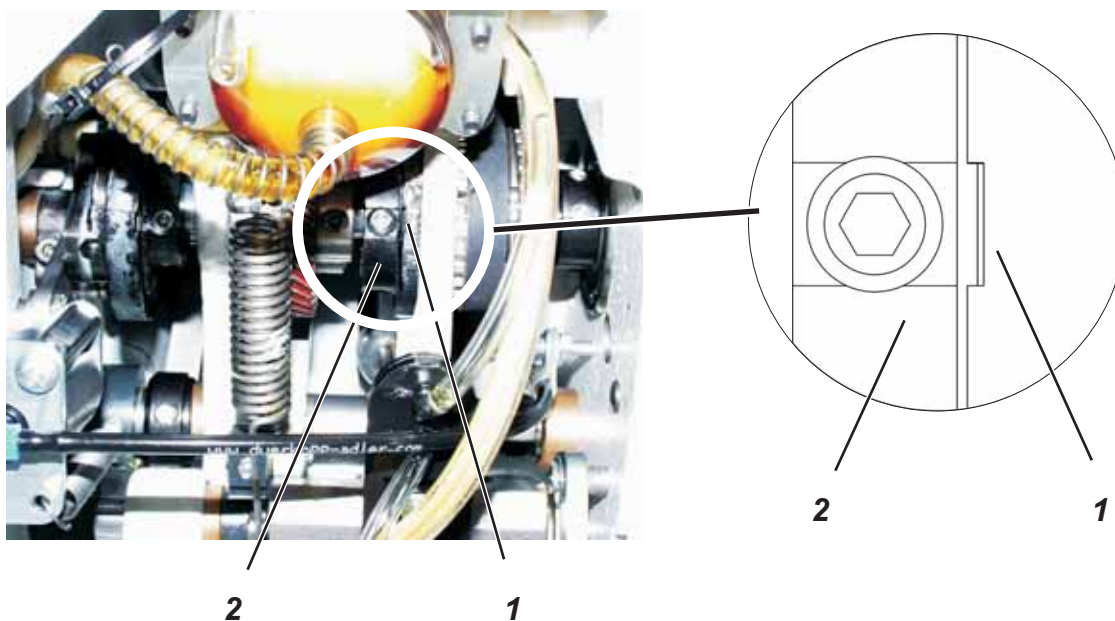

#### **Caution: Risk of injury!**

Turn off the main switch.

Check and set the feeding motion of the feed dog only when the machine is switched off.

#### **Standard checking**

The markings on the eccentric 2 and the connecting rod 1 should lie next to each other when the machine is in “looping stroke position”.

- Arrest the machine head in “looping stroke position”.
- Check the position of the markings.

#### **Correction**

- Loosen the screws on the thrust eccentric 2.
- Adjust the thrust eccentric 2.
- Tighten the screws on the thrust eccentric 2.
- Check the position of the markings.

### 2.3.5 Lifting motion of the feed dog

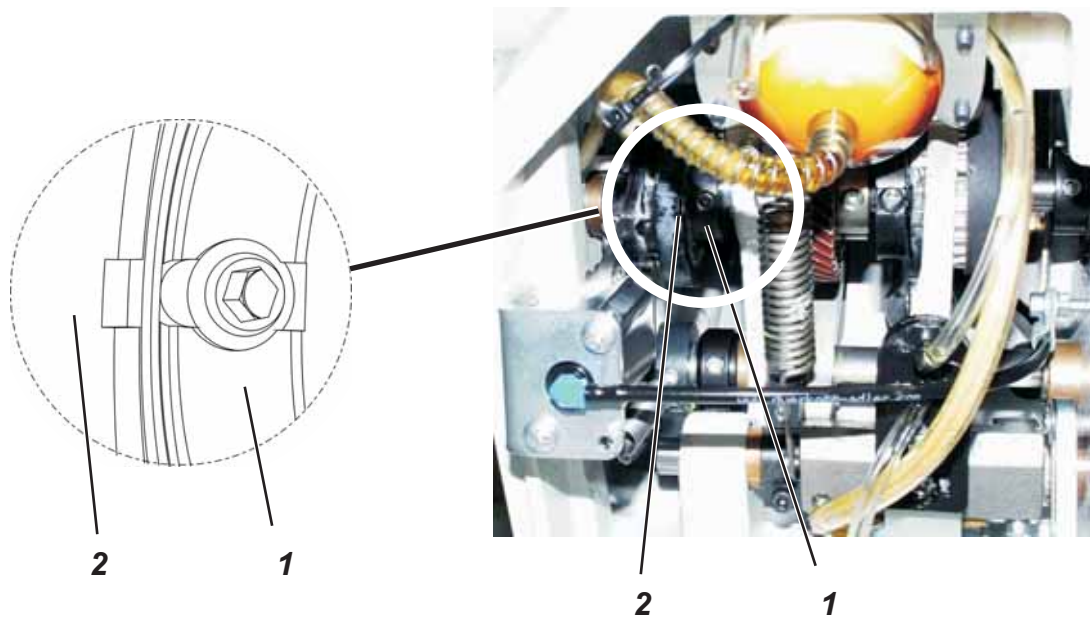

#### **Caution: Risk of injury!**

Turn off the main switch.

Check and set the lifting motion of the feed dog only with the sewing machine switched off.

GB

#### **Standard checking**

The markings on the eccentric 1 and the connecting rod 2 should lie next to each other when the machine is in "looping stroke position".

- Arrest the machine head in "looping stroke position".
- Check the position of the markings.

#### **Correction**

- Loosen the screws on the lifting cam 1.
- Adjust the lifting cam.
- Fasten screws on the lifting cam 1.
- Check the position of the markings.

### 2.3.6 Feed dog height



3

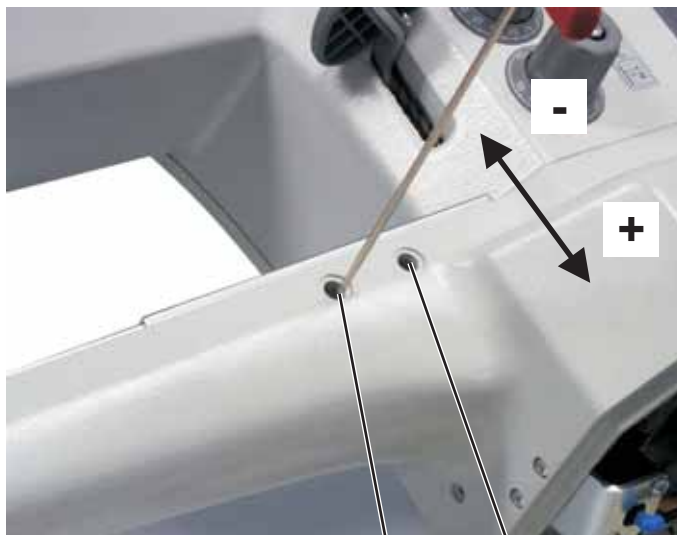

2

1



#### **Caution: Risk of injury!**

Turn off the main switch.

Check and set the feed dog height only when the machine is switched off.

#### **Standard checking**

##### ***Machines without feed dog stroke***

The feed dog should have the same height as the throat plate.

##### ***Machines with feed dog stroke***

For a safe forward movement of the material the feed dog 3 must in its highest position be 0.6 – 0.7 mm above the throat plate surface.

- Turn the handwheel until the feed dog 3 has reached its highest position.
- Check the feed dog height 3.

#### **Correction**

- Arrest the sewing feet in lifted position.
- Turn the handwheel until the feed dog 3 has reached its highest position.
- Loosen the screws 1 and 2 on the arm.
- Adjust the screw 1 (upwards or downwards), so that the feed dog stands 0.6 – 0.7 mm above the throat plate.
- Fasten screws 1 and 2.

### 2.3.7 Neutralizing the feed dog stroke

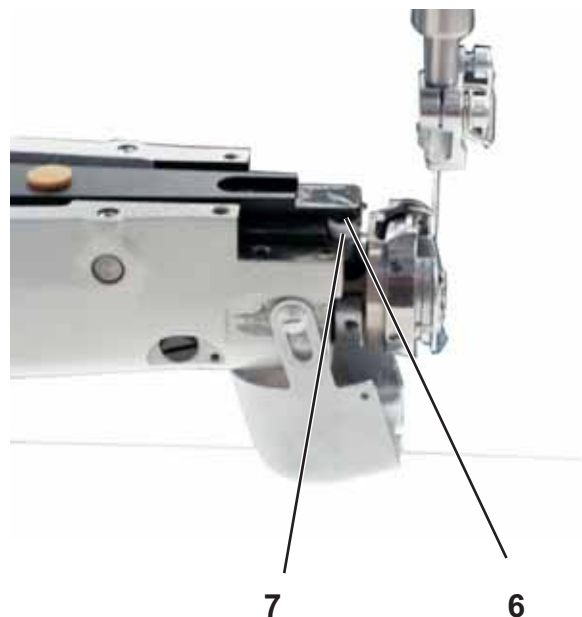
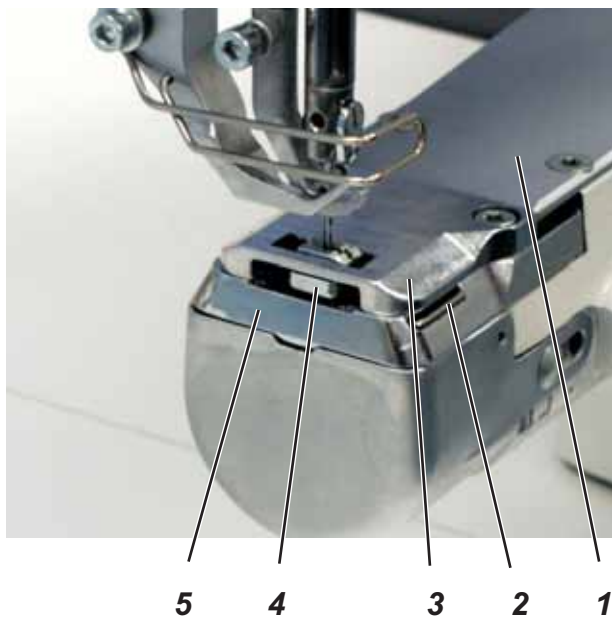

#### **Caution: Risk of injury!**

Turn off the main switch.

The removal of the slide for the feed dog should only be done with the sewing machine switched off.

**GB**

The feed dog stroke can be neutralized through removing the slide 7 for example for binding operations.

- Remove the cover 1, throat plate 3, feed dog 4 and throat plate base 5.
- Remove the slide 7.  
For this purpose, unscrew both screws 6 and take out the slide 7.
- Replace the throat plate base 5 against the throat plate base 0669 200204.  
(The throat plate base is part of the sewing equipment 669- E4/6 and 669- E 5/6).
- With machines equipped with thread trimmer, screw on the counter knife 2 and set the cutting pressure (see chapter 2.14.4).
- Screw on the feed dog 4, throat plate 3 and cover 1.

## 2.4 Transmission lever

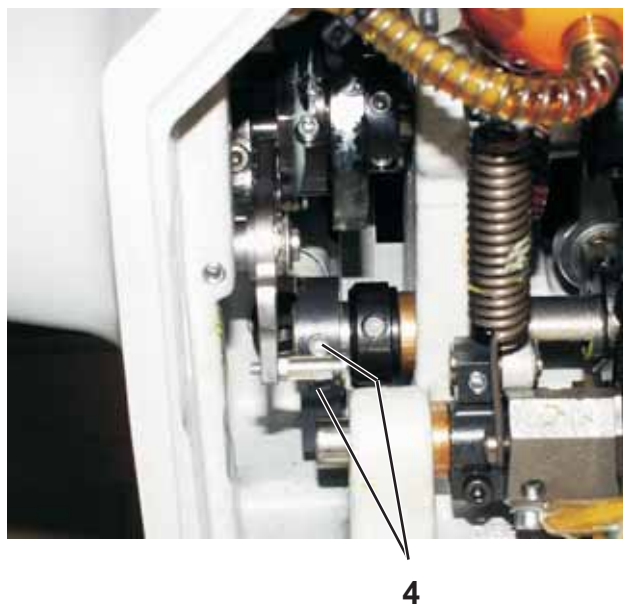
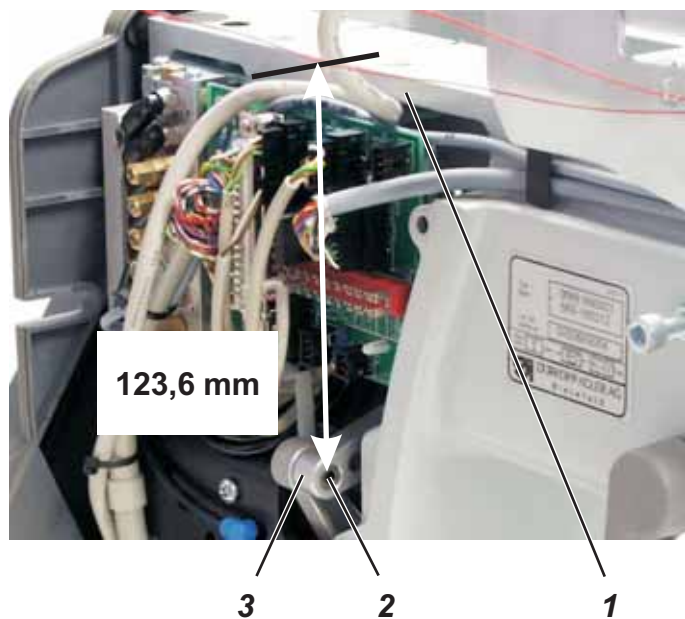

### Caution: Risk of injury!

Turn off the main switch.

Check and set the transmission lever only when the machine is switched off.



### Standard checking

The lever 3 transmits the movement of the advance shaft to the needle bar linkage.

The lever 3 must be positioned in a way that the distance between the surface of the arm 1 and the center of the bolt 2 is 123,6 mm with the stitch length set to "0".

- Set the stitch length to "0".
- Check the distance between the top edge 1 and the bolt center 2.

### Correction

- Loosen the screws 4 at the lower transmission lever.
- Loosen the screw 5 at the upper transmission lever.
- Adjust the lever 3 to fit the given dimension.
- Fasten screws 4 and 5 again.

## 2.5 Needle bar linkage

### 2.5.1 Align the needle bar linkage laterally

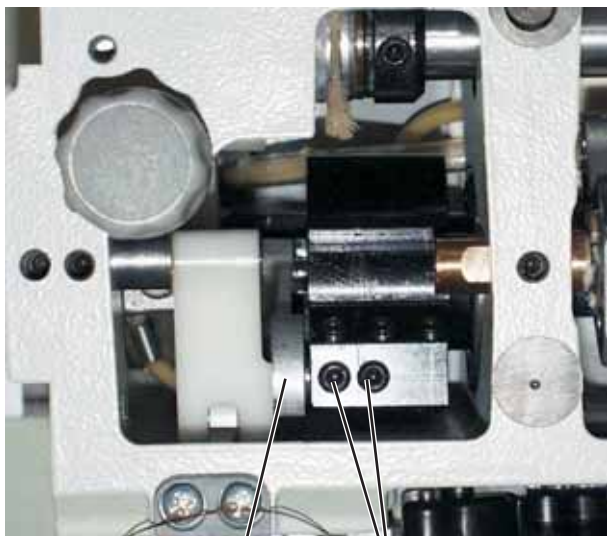

2

1

4

3



#### Caution: Risk of injury!

Turn off the main switch.

Check and set the needle bar linkage only with the sewing machine switched off.

GB

#### Standard checking

The needle must penetrate the center of the feed dog's stitch hole.

- Insert a new needle.
- Turn down the needle bar via the handwheel.
- Check the lateral position of the needle in the stitch hole.

#### Correction

- Loosen the screws on the adjustment rings 3 and 4.
- Adjust the lateral position of the needle bar linkage in a way that the needle stands in the center of the stitch hole.
- Fix the adjustment rings 3 and 4 and tighten the screws.
- Loosen screw 1.
- Adjust the thread lever laterally in a way that the clearance of the connection rod 2 on the cross head is identical to both sides.
- Fasten screws 1.



#### Attention Danger of Breakage!

Check the distance between the hook tip and the needle after adjusting the lateral position of the needle bar linkage. It may possibly be necessary to readjust the distance (see chapter 2.6.3).

## 2.5.2 Needle penetration in feeding direction



2

1

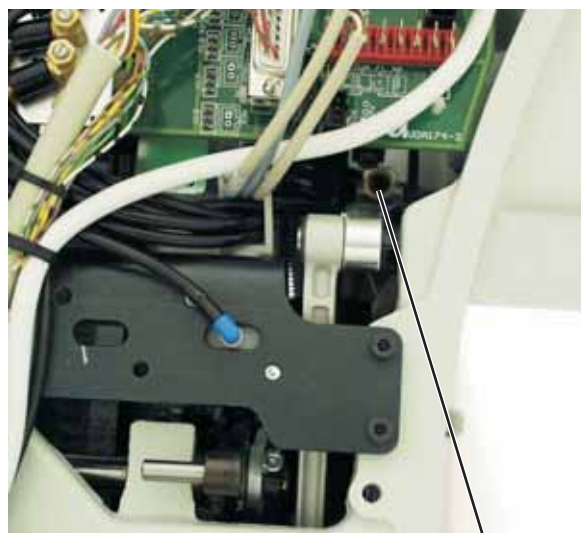

3



### **Caution: Risk of injury!**

Turn off the main switch.

Check and set the needle penetration only when the machine is switched off.

### **Standard checking**

The needle 1 should penetrate the center of the feed dog's stitch hole with the stitch length set to "0".

- Set the stitch length to "0".
- Insert a new needle.
- Turn down the needle bar via the handwheel.
- Check the position of the needle in the stitch hole.

### **Correction**

- Loosen the screw 3 at the upper transmission lever.
- Adjust the position of the needle bar linkage 2 in a way that the needle 1 stands in the center of the stitch hole.
- Fasten screw 3 again.

## 2.6 Hook, looping stroke and needle bar height

### 2.6.1 Looping stroke, distance between the hook tip and needle

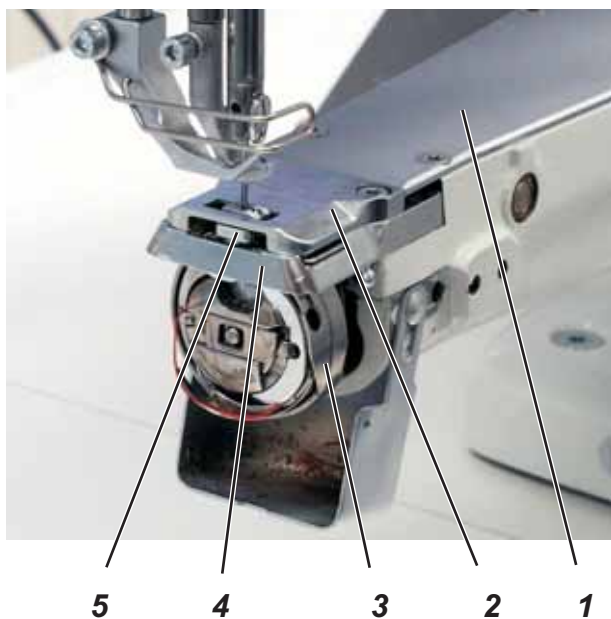

#### Caution: Risk of injury!

Turn off the main switch.

Check and set the looping stroke and the distance between the hook tip and needle, only with the sewing machine switched off.

GB

#### Standard checking

The looping stroke is the way of the needle bar from its bottom dead center to the point where the hook tip 2 is at the middle of the needle 1. The looping stroke is 2 mm.

At looping stroke position, the distance between the hook tip and the needle scarf should be 0.1 mm.

- Arrest the machine head in position I (put the locking pin  $\varnothing$  5 mm into the large groove).
- Set the stitch regulator lever or the stitch length setting wheel to "0".
- Check the position of the needle in relation to the hook tip.

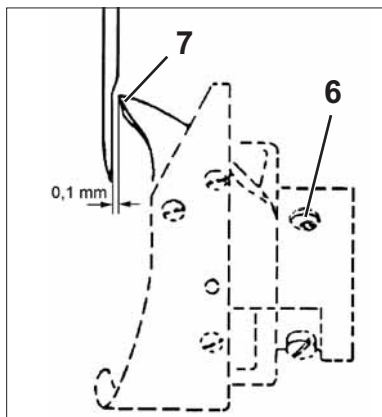

#### Correction distance between the hook tip and needle.

- Remove the cover plate 1, throat plate 3, feed dog 4 and throat plate base 5.
- Take the bobbin case out of the hook.
- Loosen the fastening screws 6 of the hook using an Allen key of 3 mm.  
The first screw in the direction of rotation is on a flat spot.
- Insert a new needle.
- Set the stitch regulator lever or the stitch length setting wheel to "0".
- Arrest the sewing machine in looping stroke position (arresting position I).
- Turn the hook in a way that the hook tip 7 stands in the middle of needle 1.  
The distance between the hook tip 7 and the needle scarf should be 0.1 mm.
- Fasten the fastening screws 6 of the hook.

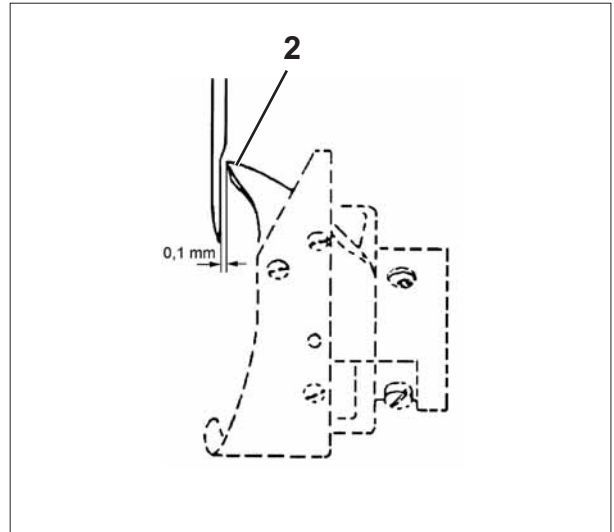
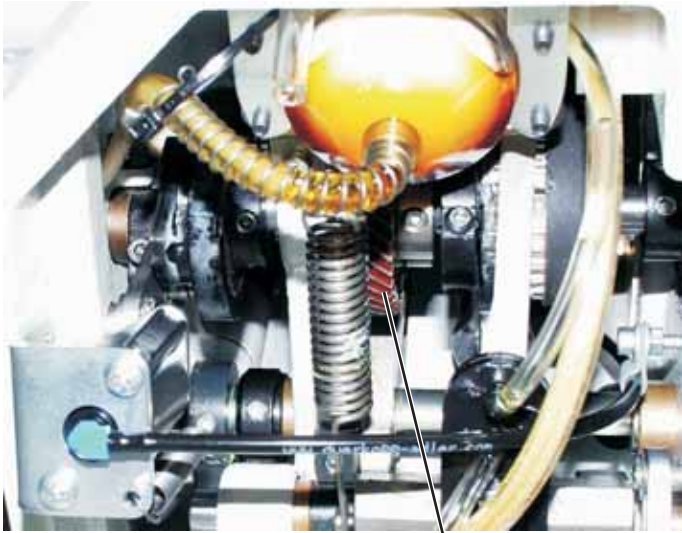

1

### Correction looping stroke setting

- Loosen screws on the toothed wheel 1.
- Arrest the machine head in position I by putting the locking pin  $\varnothing$  5 mm into the large groove.
- Set the stitch regulator lever or the stitch length setting wheel to "0".
- Set the hook in a way that the hook tip 2 stands in the middle of the needle.
- Fasten screws on the toothed wheel 1.
- Mount all the dismantled parts again.

## 2.6.2 Needle bar height

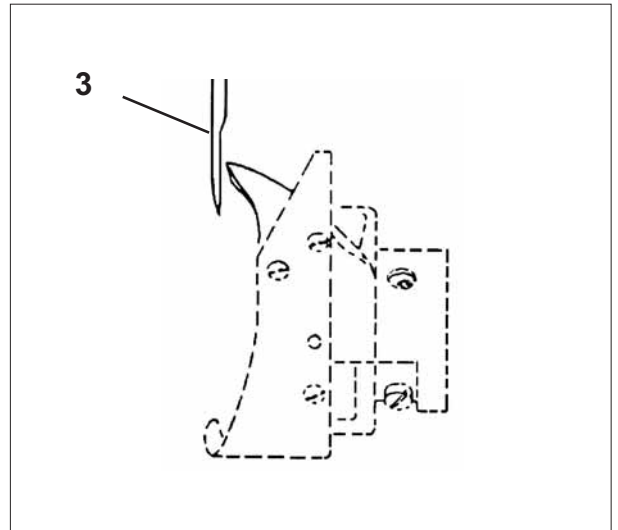
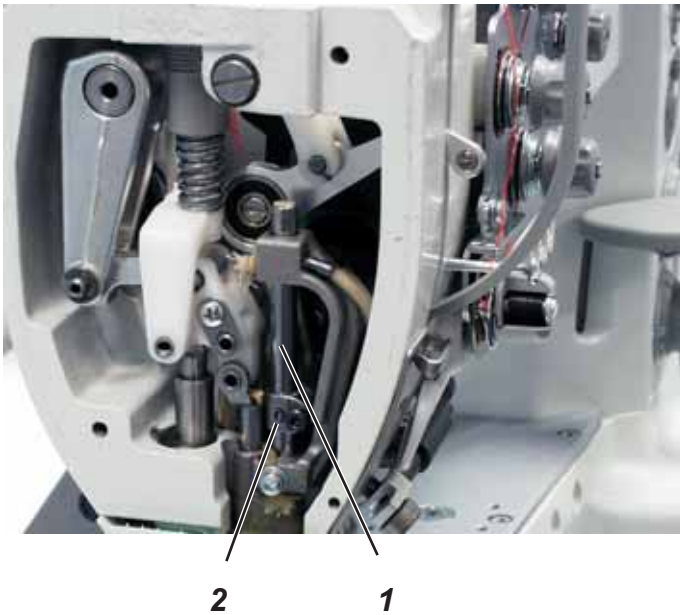

### Caution: Risk of injury!

Turn off the main switch.

Check and set the needle bar height only when the machine is switched off.

GB

### Standard checking

The needle bar's height is to be set in a way that the hook tip stands in the lower third of the needle scarf with the stitch length set to the largest one and the machine in the looping stroke position.

- Set the stitch regulator lever or the stitch length setting wheel to "largest stitch length".
- Arrest the sewing machine at locking position I (looping stroke position).
- Check the position of the needle in relation to the hook tip.

### Correction

- Set the stitch regulator lever or the stitch length setting wheel to "largest stitch length".
- Arrest the sewing machine at locking position I (looping stroke position).
- Unscrew the face cover.
- Loosen the fastening screw 2 of the needle bar.
- Shift the needle bar 1 with needle 3.  
Upon shifting, the needle bar must not be twisted.  
The needle scarf must be directed to the hook tip.
- Tighten the fastening screw of the needle bar.

A wrong setting of the needle bar height can have the following effects:

- Damage on the hook tip.
- Jamming of the needle thread between needle and needle guard.
- Skip stitches and thread breakage.

## 2.7 Throat plate base

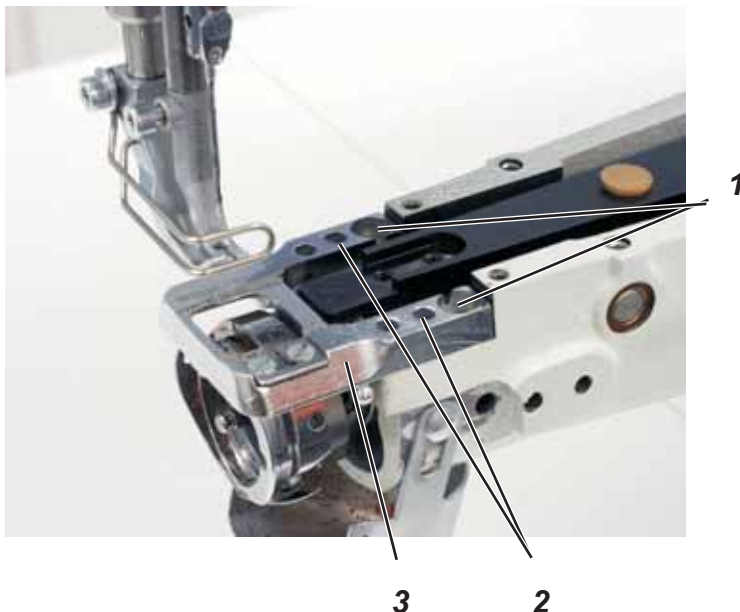
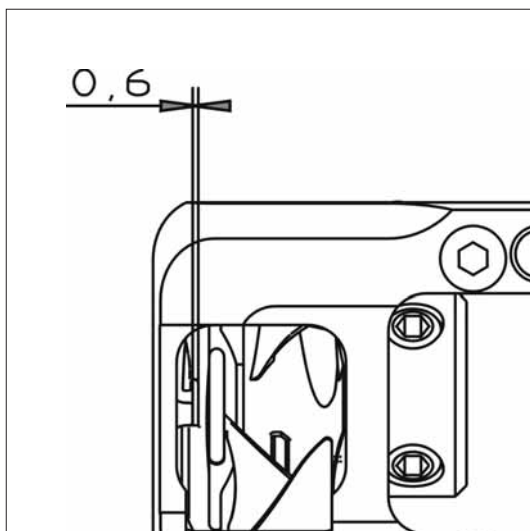

### **Caution: Risk of injury!**

Turn off the main switch.

Check and correct the bobbin case support only with the sewing machine switched off.

### **Standard checking**

There should be enough clearance between the bobbin case and the lug of the bobbin case (lug integrated in the throat plate base 3), so that the needle thread can be unhindered pulled through.

### **Correction**

- Loosen screw 1.
- Loosen screw 2.
- Align the throat plate base 3.  
(Clearance 0.6 mm, see sketch)
- Fasten screws 1.
- Fasten screws 2.

## 2.8 Feeding foot and presser foot

### 2.8.1 Feeding foot and presser foot stroke



2

1



4

3



#### Caution: Risk of injury!

Turn off the main switch.

Check and set the sewing foot stroke only with the sewing machine switched off.

GB



5

#### Standard checking

The strokes of both sewing feet should be identical when the setting wheel 5 is set to "3".

- Set the stitch length to "0".
- Set the medium sewing foot pressure.
- Set the sewing foot stroke on the setting wheel 5 to "3".
- Turn the handwheel and compare the strokes of the sewing feet 1 and 2.  
The strokes of the presser foot 1 and the feeding foot 2 should be identical.

#### Correction

- Unscrew and remove the arm cover 1.
- Turn the handwheel to position 0°.
- Loosen the screw 3.
- Push the feeding foot 2 completely onto the throat plate.
- Fasten the screw 3.
- Fix the arm cover.
- Turn the setting wheel to position "3".
- Check whether both strokes are identical.  
If not, readjust the setting.

## 2.8.2 Stroke motion of the feeding foot



2

1



3



### **Caution: Risk of injury!**

Turn off the main switch.

Check and set the stroke motion of the feeding foot only with the sewing machine switched off.

### **Prerequisite**

- The strokes of the feeding foot 1 and the presser foot 2 must be set (see chapter 2.8.1).
- Correct timing of the feeding dog's lifting motion (see chapter 2.3.5).

### **Rule**

The feeding foot 1 should reach the level of the throat plate at the same time as the following elements:

- With the upward going feed dog.
- With the downward going needle point.

### **Checking**

- Set the maximum stitch length.
- Set the greatest sewing-foot stroke.
- Turn the handwheel and check the stroke motion. The above mentioned requirements must be fulfilled.

### **Correction**

- Loosen the screws on the lifting cam 1 (not visible, 2 pieces).
- Twist the lifting cam 1 accordingly.

### **ATTENTION!**

The lifting cam 1 must not be shifted axially.

- Fasten screws on the lifting cam 1.
- Check the setting and correct it if needed.

### 2.8.3 Sewing foot pressure

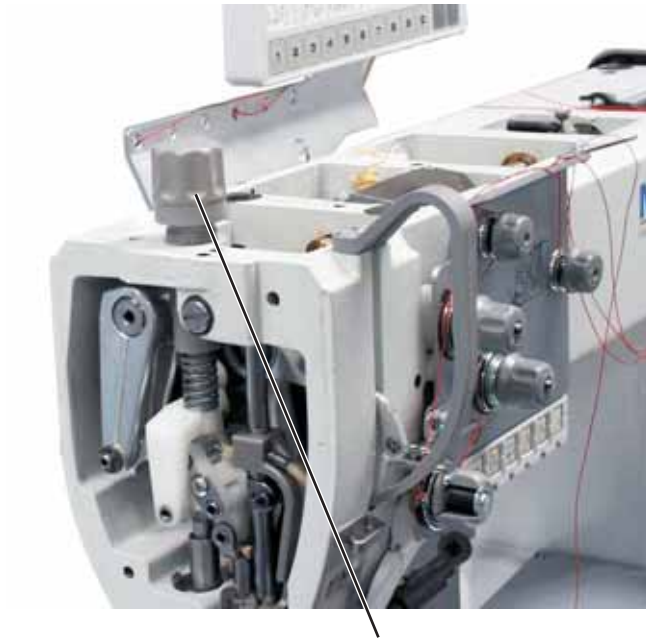

**1**

#### **Standard checking**

The material that is to be sewn must not “float”.  
It should not be exerted more pressure than necessary.

#### **Correction**

- Set the sewing foot pressure by turning screw 1.  
Increase the pressure = Turn screw 1 clockwise.  
Decrease the pressure = Turn screw 1 counter-clockwise.

**GB**

## 2.9 Stitch length limitation

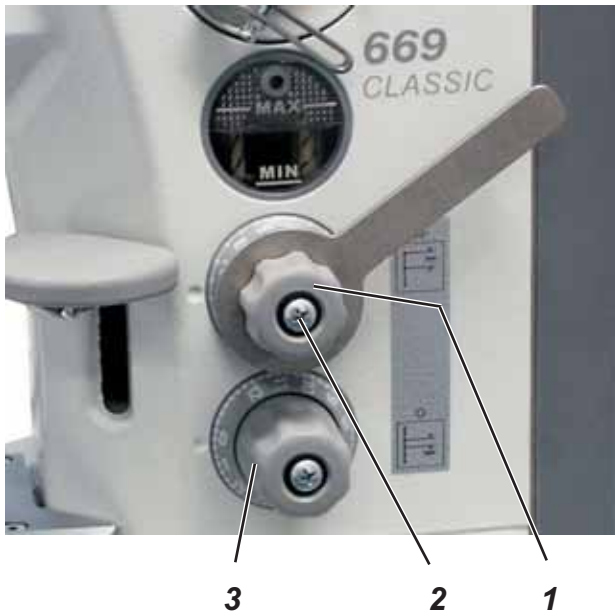

Depending on the sewing equipment used, the stitch length setting has to be limited to 6 or 9 mm.

- Unscrew the screw 2 on the stitch length setting wheel.
- Pull off the setting wheel 1.
- Unscrew the threaded pin 4 and screw it into the corresponding bore hole.  
The bore holes are numbered showing the corresponding max. stitch length.
- Carry out the setting according to chapter 2.3.1 "**Basic setting of stitch adjustment**".
- Put setting wheel on again and tighten it with screw 2.

## 2.10 Stitch equality of the forward and backward stitch

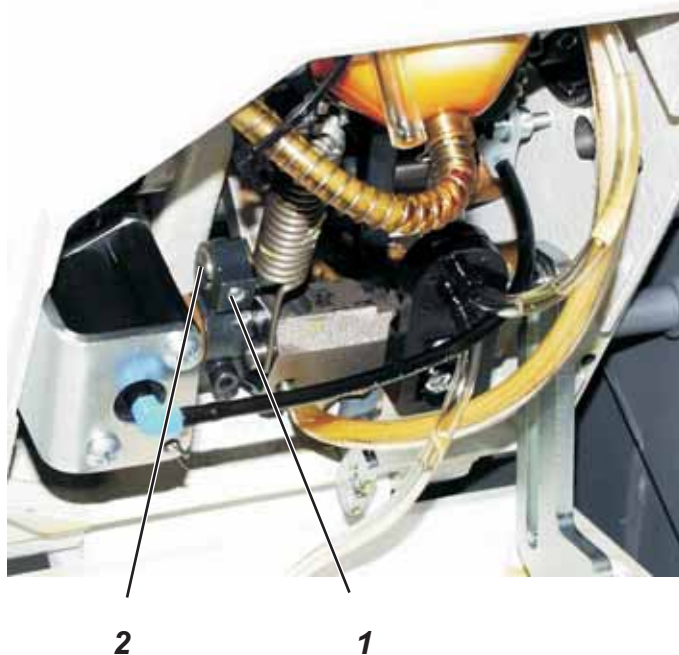

### **Caution: Risk of injury!**

Turn off the main switch.

The stitch equality may only be adjusted with the sewing machine switched off.

GB

### **Standard checking**

The stitch length of the forward and backward stitch should be identical.

- Sew forwards.
- Sew backwards.
- Compare the stitch lengths of both seams.

### **Correction**

- Loosen the screw 1.
- Turn the eccentric 2 using a screw driver.  
Clockwise =  
Backward stitch larger, forward stitch smaller.  
  
Counter-clockwise =  
Forward stitch larger, backward stitch smaller.
- Fasten the screw 1.
- Sew forwards.
- Sew backwards.
- Compare the stitch lengths of both seams.

## 2.11 Sewing foot lifting

### 2.11.1 Mechanical sewing foot lifting

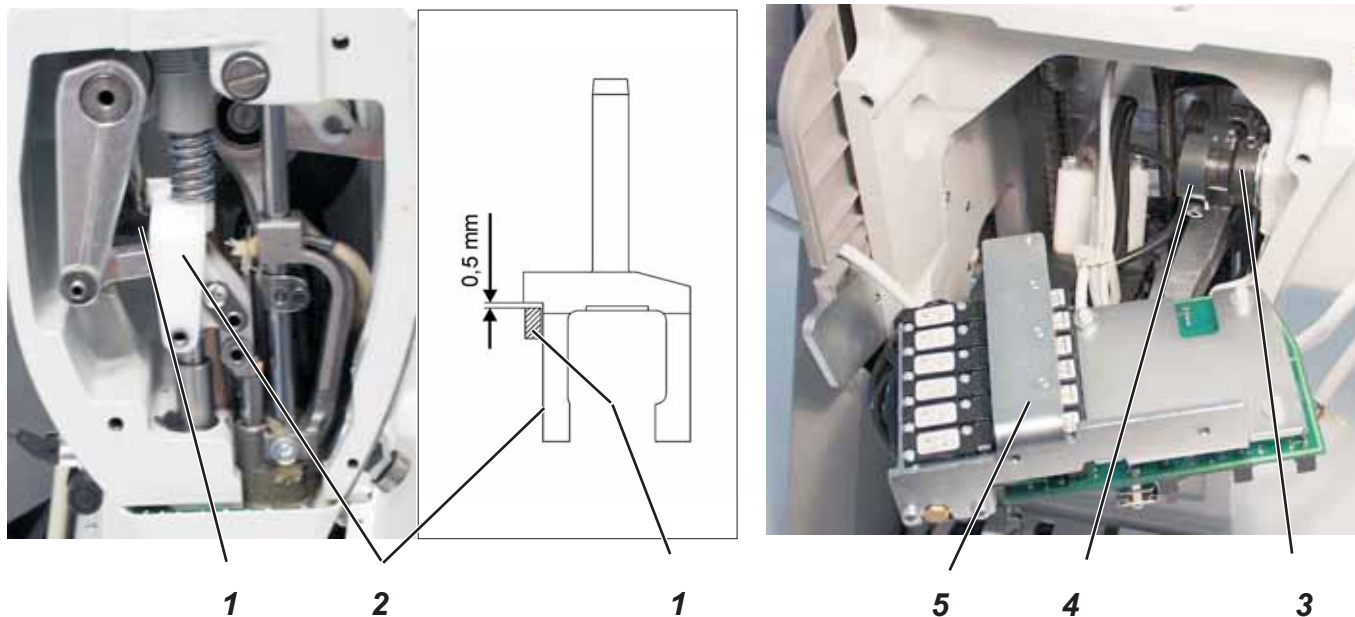

#### Caution: Risk of injury!

Turn off the main switch.

Check and set the clearance of the lifting mechanism only with the sewing machine switched off.

#### Standard checking

The lifting shaft 6 is supposed to run softly but should have no end play.

The clearance in the lifting mechanism should be approximately 0.5 mm between the spring guide 2 and the lifting lever 1.

- Lower the sewing feet.
- Turn the handwheel until the presser foot touches down.
- Move the lifting shaft 6 and check its clearance.

#### Correction

##### **Tightening the lifting shaft**

- Unscrew the electric and pneumatic unit 5.
- Loosen the screw on the adjustment ring 3.
- Push the lifting shaft 6 completely to the right (see the arrow), push the adjustment ring 3 close to the bearing bush and tighten it.

##### **ATTENTION!**

The shaft must still run softly.

##### **Clearance for the lifting shaft**

- Loosen the screws on the lifter block 4.
- Twist the lifting shaft 6 until it has the clearance needed.
- Tighten the screws on the lifter block 4.

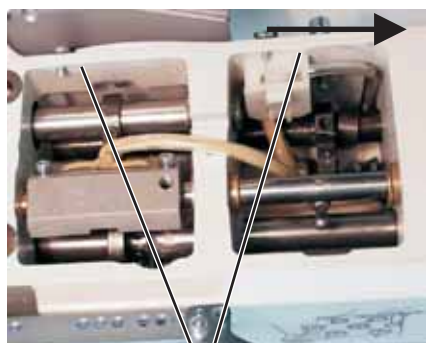

6

## 2.11.2 Height of the sewing feet arrested with hand lever



1



3

2



### Caution: Risk of injury!

Turn off the main switch.

Check and set the sewing foot lifting only with the sewing machine switched off.

GB

### Standard checking

The sewing feet 4 are arrested in lifted position with the hand lever 1 for example in order to exchange the sewing feet or to run the sewing machine without any material or to wind up the hook thread.

When arrested in lifted position with the hand lever the sewing feet 4 are supposed to have a distance of 9 mm to the throat plate.

- Bring both sewing feet to the same level.
- Lift the sewing feet with the hand lever and arrest them.
- Check the lifting height.



4

### Correction

- Lift the sewing feet.
- Put a spacer (9 mm) under the sewing feet 4.
- Loosen the screws on the lifting lever 3.
- Push down the lifting lever 1.
- Press the lever 3 onto the eccentric cam 2.
- Fasten the screws on the lifting lever 3.

### 2.11.3 Height of the lifted sewing feet



2

1



3



#### **Caution: Risk of injury!**

Turn off the main switch.

Check and set the height of the lifted sewing feet only with the sewing machine switched off.



4

#### **Standard checking**

The pneumatically driven or via knee lever lifted sewing feet 4 are supposed to have a distance of 20 mm to the throat plate when the needle bar is in its upper dead center.

The screw 2 limits the path of the lifting lever 3.

- Lower the sewing feet.
- Turn the handwheel until the needle bar is in its upper dead center.
- Lift the sewing feet pneumatically or via knee lever and check the lifting height.

#### **Correction**

- Loosen the counter nut 1.
- Twist the stop screw 2 accordingly.
- Fasten the counter nut 1.

## 2.12 Thread-guiding parts

### 2.12.1 Thread regulator

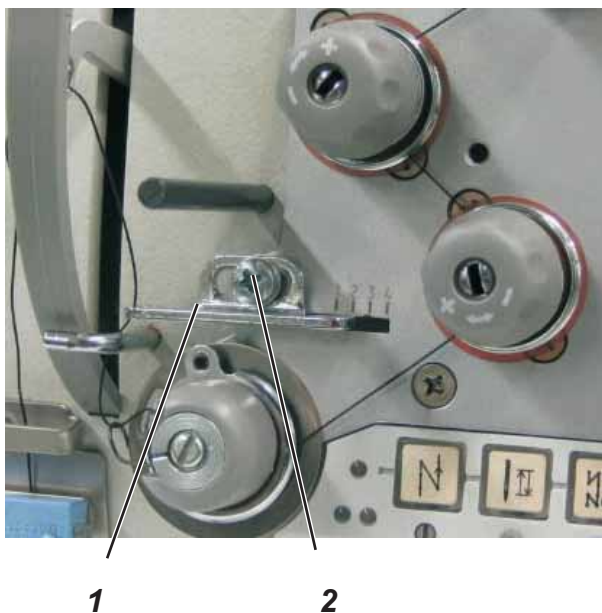

#### **Caution: Risk of injury!**

Turn off the main switch.

Check and set the thread regulator only with the sewing machine switched off.

#### **Standard checking**

The position of the thread regulator 1 depends on the thickness of the material to be sewn, the thread size and the chosen stitch length. It has to be set so that the thread is guided around the hook and kept under control.

In position "1" occurs the highest thread output as needed with particularly large stitch lengths and thick sewing threads.

- Position the material.
- Thread in the needle and hook thread.
- Open the throat plate slide.
- Turn the handwheel slowly and observe how tight the thread is guided around the hook.

#### **Correction**

- Loosen the screw 2.
- Shift the thread regulator.  
Thread regulator to the left = more thread.  
Thread regulator to the right = less thread.
- Fasten the screw 2.

## 2.12.2 Thread take-up spring

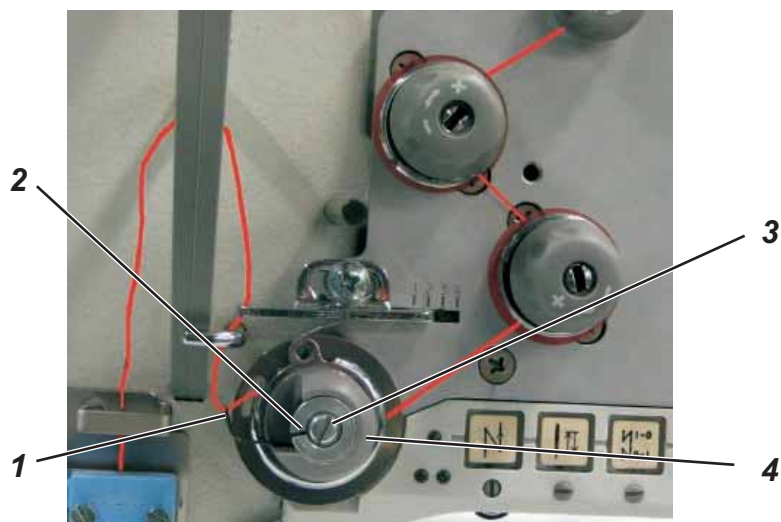

### **Caution: Risk of injury!**

Turn off the main switch.

Check and set the thread take-up spring only when the machine is switched off.

### **Standard checking**

The standard setting for the spring travel and spring tension only apply to usual thread sizes.

Very thick or very thin threads or sewing material may require different settings.

### **Spring travel**

The thread take-up spring 1 has to keep the needle thread from the moment of the thread lever lifting until the needle eye's penetrating of the material under a light tension.

In order to achieve a regular seam with a low thread tension, the travel of the thread take-up spring may be increased.

The thread take-up spring must only meet the stop when the needle eye has penetrated the material.

### **Spring tension**

The spring tension should be lower than the thread tension.

### **Correction**

#### **Spring travel**

- Loosen the screw 2.
- Turn the stopping collar 4.  
Turning counter-clockwise = larger travel  
Turning clockwise = smaller travel.
- Fasten the screw 2.

#### **Spring tension**

- Loosen the screw 2.
- Adjust the tension disc 3 without changing the stopping collar's 4 position.  
Turning the disc clockwise = less spring tension  
Turning the disc counter-clockwise = higher spring tension

- Tighten screw 2 without changing the positions of the stopping collar 4 and the tension disc 3.

## 2.13 Bobbin winder



5 4 3 2 1

6



### Caution: Risk of injury!

Turn off the main switch.

Check and set the bobbin winder only with the sewing machine switched off.

### Standard checking

The bobbin winding operation must stop automatically when the bobbin is filled up to approx. 0.5 mm below the bobbin edge.

The winder wheel must not have end play but its moving should not be to sluggish either.

### Basic setting

- Disassemble the bobbin winder.  
In order to do so unscrew the two fastening screws 1 and 5 and pull the winder off.
- Screw in the screw 4 until the two arms of the winder flap 3 come parallel to each other.
- Insert a completely filled bobbin on the winder.
- Twist the winder flap 3 so that it bears against the thread on the bobbin.
- Loosen the screw 7.
- Set the switching cam 11 so that the corner 10 of the switching cam and the corner 8 of the leaf spring 9 superpose (the spring is loaded) and the winder flap 3 has no end play.
- Fasten the screw 7.

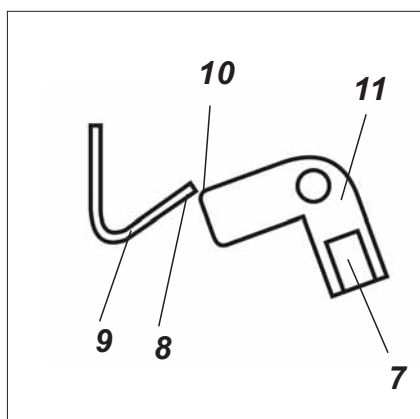



4 3 12 1

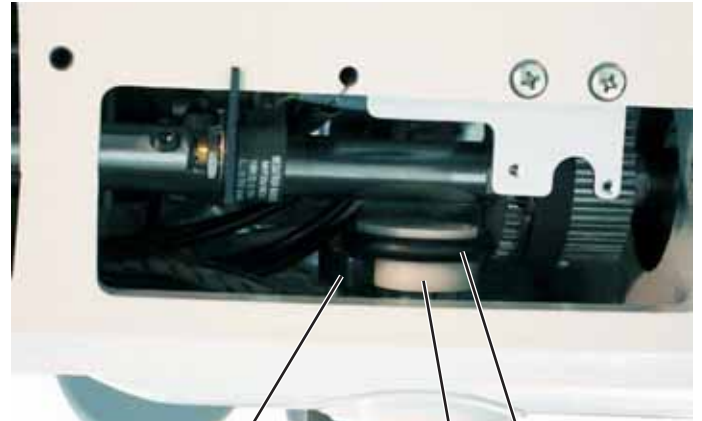

14 13 6

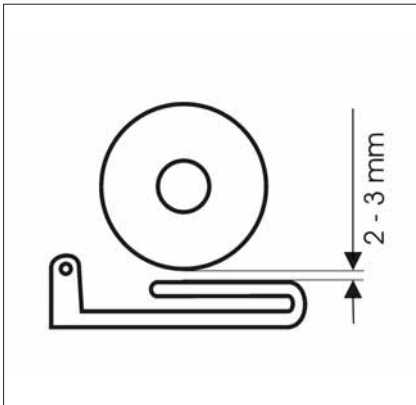

- Turn the spindle so that the tear-off knife 12 points to the fastening screw 1 on the right side.
- Loosen the screw on the engagement block 14.
- Set the winder flap so that between the thread on the bobbin and the winder flap remains a distance of 2 - 3 mm (insert a spacer).
- Set the engagement block 14 so that it bears on the locking disc 13 and has an end play of 0.5 mm towards the winder wheel 6.
- Tighten the screw on the engagement block.
- Screw the bobbin winder on again.

GB

#### Small changes of the bobbin wind-on quantity

- Adjust the winder flap 3 with the screw 4.

#### Correction of the winder's pretension position

The guide must be set in a way that the bobbin is evenly filled with thread over its whole width.

- Loosen the screw 17.
- Adjust the guide 16.
- Fasten the screw 17.



17 16



3

2

1

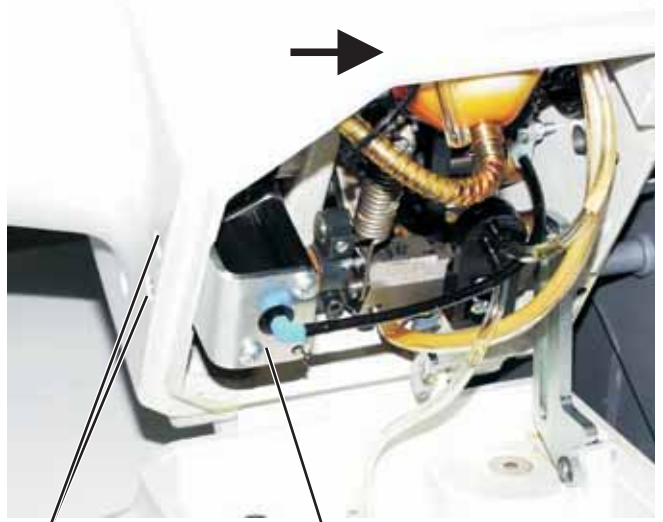

5

4



6



7

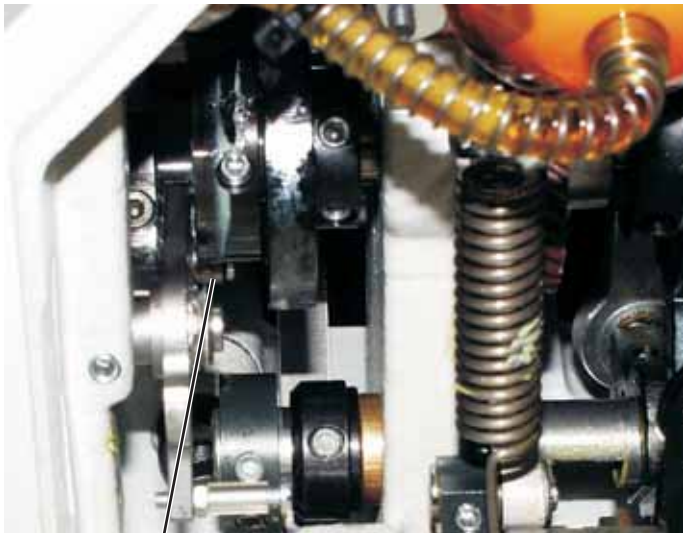

8

## 2.14 Thread trimmer

### 2.14.1 Mechanical part



#### **Caution: Risk of injury!**

Turn off the main switch.

Check an set the thread trimmer only with the sewing machine switched off.

#### **Standard checking**

The hollow shaft in the arm should have no play.

- Unscrew the plate 3.
- Check the play of the hollow shaft.

#### **Correction**

- Unclamp the spring on the cylinder 4.
- Loosen the screws 5 and remove the cylinder 4.
- Arrest the hollow shaft using the locking pin 6.
- Loosen the adjustment ring screw 2.
- Tighten the adjustment ring 1 completely to the right and fasten the screw 2.
- Loosen the clamping block 7.
- Tighten the clamping block to the left and fasten the screw.  
The roller 8 must at the same time lie against the highest place of the control cam.

#### **Please note:**

Mount the plate 3 and proceed to the setting according to chapter 2.3.3.

## 2.14.2 Thread trimmer cam position

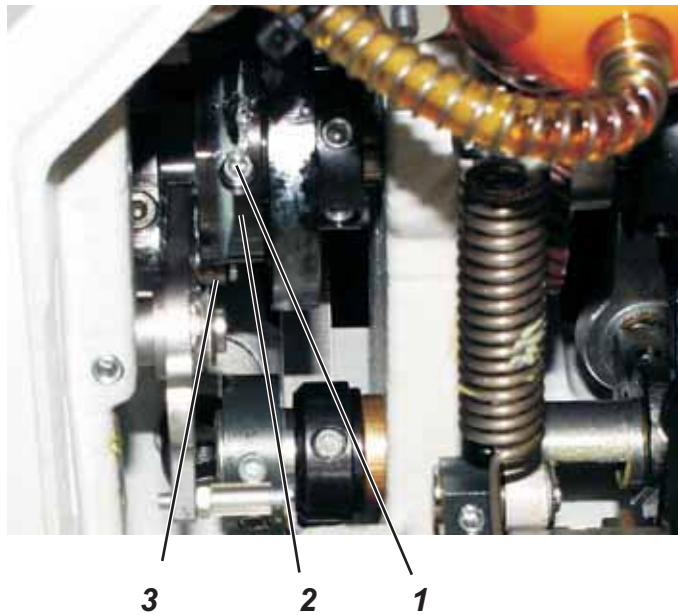

### **Caution: Risk of injury!**

Turn off the main switch.

Check and set the thread trimmer only with the sewing machine switched off.

### **Standard checking**

In the looping stroke position, the thread trimmer cam 2 is to be positioned in such a way that the roller 3 is located in the recess of the cam.

- Arrest the machine in "looping stroke position".
- Check the setting of the thread trimmer cam.

### **Correction**

- Loosen screws 1 of the thread trimmer cam.
- Twist the thread trimmer cam 2 in a way that the roller 3 is located in the recess of the cam.
- Fasten screws 1.

### 2.14.3 Play between the roller and the control cam

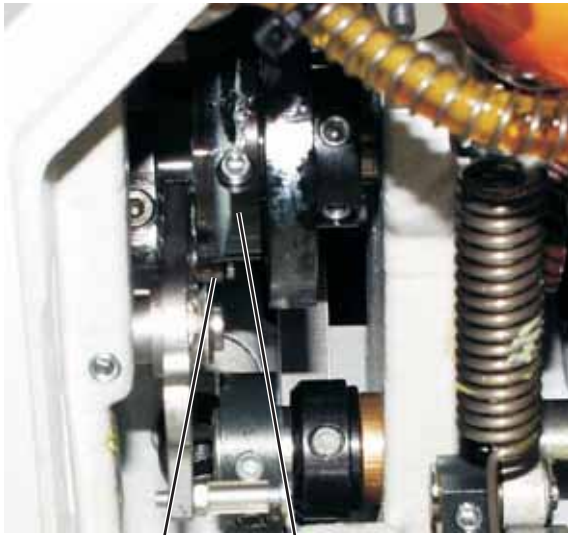

2 1

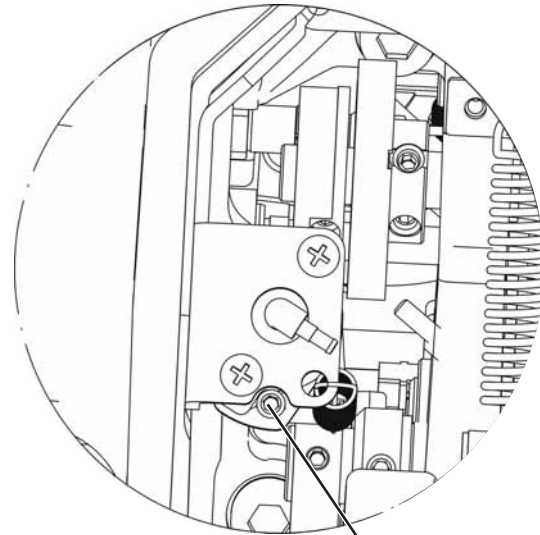

3



#### Caution: Risk of injury!

Turn off the main switch.

Check and set the thread trimmer cylinder only when the machine is switched off.

GB

#### Standard checking

The cylinder should be set in a way that between roller 2 and thread trimmer cam 1 approx. 0.1 mm clearance exists.

- Check the distance between the roller 2 and the thread trimmer cam 1.

#### Correction

- Adjust the threaded pin 3 accordingly.  
Clockwise = less distance  
Counter-clockwise = more distance
- Check the distance.

## 2.14.4 Setting the cutting pressure

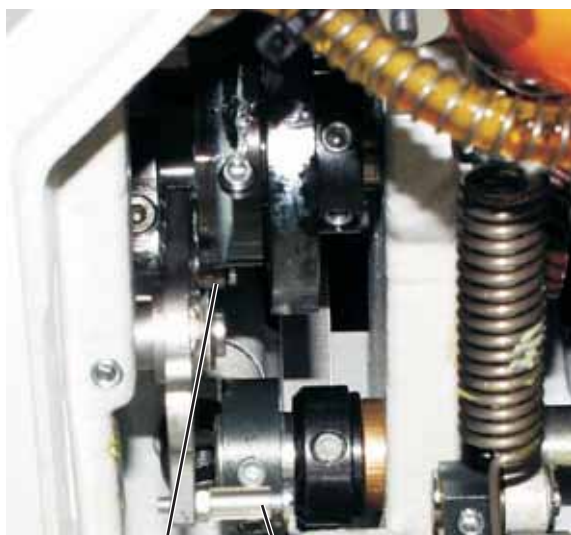

2 1



4 3



### Caution: Risk of injury!

Turn off the main switch.

Check and set the cutting pressure only when the machine is switched off.

### Standard checking

The thread is to be trimmed safely with as little pressure as possible. A low trimming pressure keeps the knife wear low!  
It must be possible to safely trim two of the thickest sewing threads simultaneously.

### ATTENTION!

If the cutting pressure is too high, the thread trimmer cylinder does not swivel out the thread-pulling knife.  
There is no thread trimming function.

- Turn the handwheel, until the thread pulling knife 3 can be swivelled in. manually.
- Press the lever 1 until the roller 2 presses into the thread trimmer cam.
- Insert two threads to be trimmed into the hook knife.
- Turn further the handwheel, until the thread pulling knife 3 is swung back.
- Check whether the sewing threads have been trimmed properly.

### Correction

- Twist the screw 4.  
Clockwise = more cutting pressure  
Counter-clockwise = less cutting pressure
- Check the setting and correct it if needed.

## 2.15 Potentiometer in the arm

Sewing machines with thread trimmer are equipped with a potentiometer in order to limit the sewing speed of higher sewing foot strokes. Through this potentiometer the control unit recognizes the sewing foot stroke and limits the sewing speed.

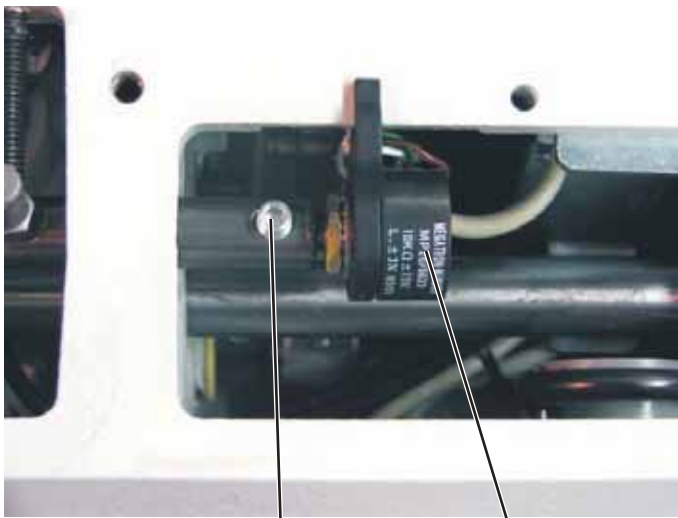

1

2



4

3

GB

### 2.15.1 Basic setting without control panel

Set sewing machines without control panel according to the following description.



#### Caution: Risk of injury!

Turn off the main switch.

Set the potentiometer only with the sewing machine switched off.

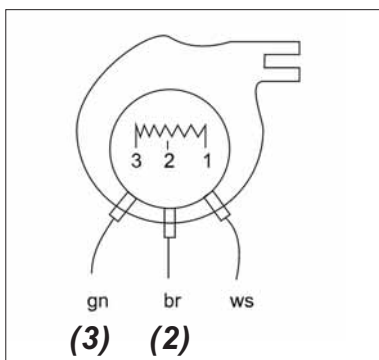

- Pull out the plug 3 of the potentiometer on the PCB 4.
- Check the resistance on the terminals (2) and (3) of the potentiometer with an ohmmeter.  
Terminal (3) = green wire  
Terminal (2) = brown wire

Measuring value: 7.1 to 7.3 kOhm

If the values mentioned are not correct the potentiometer's 2 position is to be adjusted.

- Loosen the screw 1.
- Set the shaft of the potentiometer 2 to the corresponding value.
- Push the potentiometer completely into the bore hole of the setting shaft and tighten screw 1.
- Plug in the plug 3 of the potentiometer on the PCB 4.

## 2.15.2 Basic setting with the control panel V810 or V820

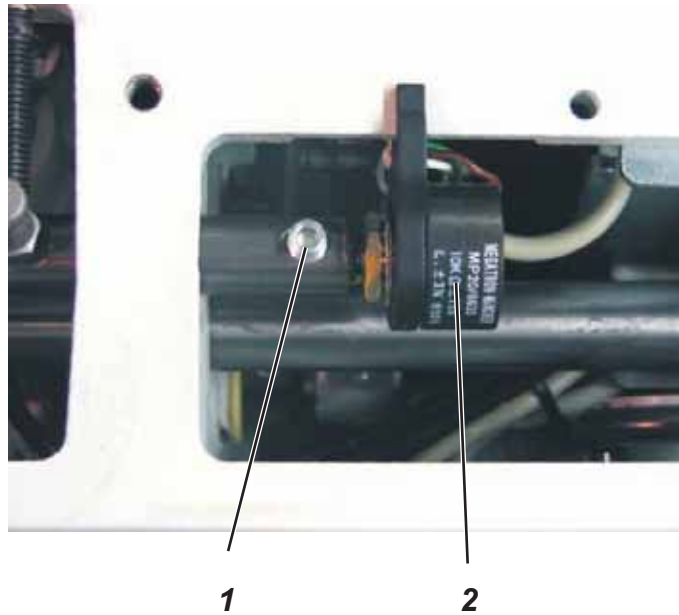

### **Caution: Risk of injury!**

The adjustment of the potentiometer is carried out with the main switch turned on.

Work with utmost caution.

- Loosen the stop screw 1 for the potentiometer 2.
- Keep the key “P” pressed and turn on the main switch.
- Enter the technician level.
- Select the parameter “F-188”.
- Actuate the key “E”.  
The current Speedomat grade (e.g. 11) and the corresponding sewing speed limitation (e.g. 2860) are displayed.
- Turn the potentiometer shaft until the Speedomat grade “07” and the corresponding maximum sewing speed of 3800 rpm resp. 3400 rpm (depending on the subclass) are indicated on the display.
- Tighten the stop screw 1.
- Check the setting.

### 2.15.3 Check the potentiometer adjustment



- Keep the key "P" pressed and turn on the main switch.
- Enter the technician level.
- Select the parameter "F-188".
- Actuate the key "E".  
The current Speedomat grade and the corresponding sewing speed limitation are displayed.
- Set the setting wheel 1 to "**lowest lift stroke**".  
The display should indicate the Speedomat grade "07".
- Set the setting wheels 1 and 2 to "**maximum lift stroke**".  
The display has to indicate the Speedomat grade "21".  
For the sewing speed the display indicates "EEEE".

#### **Please note:**

If the Speedomat grades "07" and "21" cannot be attained the potentiometer must be readjusted.

## 2.16 Connections PCB

For the sake of completeness, the various connections of the PCB below are explained here.

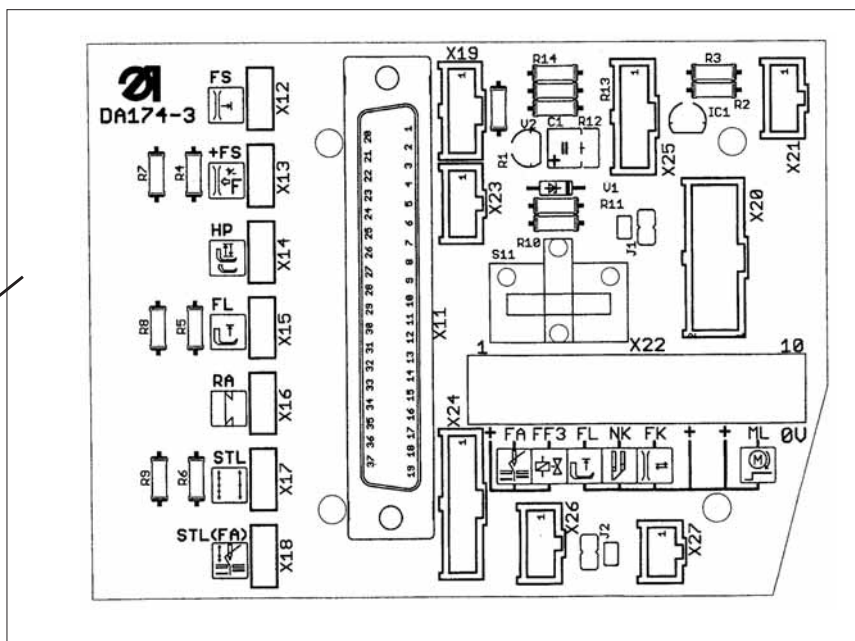
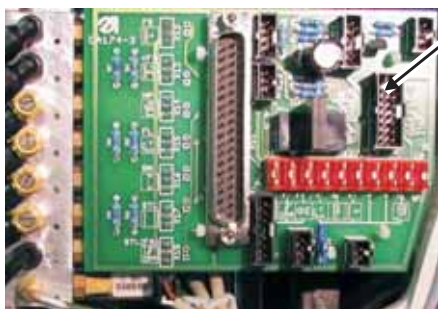

X11 Control Sewing Drive	X12 Solenoid Thread Tension	X13 Solenoid Additional Thread Tension
X14 Solenoid Stroke Adjustment Pneum.	X15 Solenoid Sewing Foot Lifting	X16 Solenoid Tack
X17 Solenoid Switching Stitch Length	X18 Solenoid Short Stitch	X19 HP-Potentiometer in the Arm (Speedomat)
X20 Key Block	X21 Light Barrier Seam End	X23 Speed Limitation Stitch Length
X22 1 +24V	2 Output Thread Trimmer	3 Output Flip-flop 3 Adjustable via Parameter 275
4 Output Sewing Foot Lifting	5 Output Needle Cooling	6 Output Thread Clamp
7 & 8 +24V	9 Output Motor Running / Signal	10 0V
<i>For each connection make sure to have one wire connected to the +24V and the other one to the output function</i>		
X24 Residual-thread monitor	X25 Oil Level Monitoring	X26 Input Machine Run Blockage (Possibility of connecting an external ext. PIN 2/3)
X27 Output for max. 50 mA		
J2 Jumper 2	Closed: bridging the input machine run blockage X26 PIN 2/3 Open: an external "trigger" button must be connected to the X26 PIN 2/3.	

### 3. Oil lubrication



**Caution: Risk of injury!**

Oil can cause skin rashes.  
Avoid longer skin contact.  
After contact wash yourself thoroughly.



**ATTENTION!**

The handling and disposal of mineral oils is subject to legal regulations.  
Deliver used oil to an authorized collecting station.  
Protect your environment.  
Be careful not to spill any oil.

To lubricate the sewing machine use only **DA-10** lubricating oil or an equivalent oil with the following specifications:

- Viscosity at 40° C: 10 mm<sup>2</sup>/s
- Ignition point : 150° C

**DA-10** can be bought at the sales points of DÜRKOPP ADLER AG under the following parts number:

250 ml container:	9047 000011
1-litre container:	9047 000012
2-litre container:	9047 000013
5-litre container:	9047 000014

GB



**1**

**Lubrication of the machine head**

- The sewing machine is equipped with a central oil wick lubrication. All bearings are supplied by the oil reservoir 1.
- The oil level must not drop below the marking "**MIN**".
- Fill up oil up to the marking "**MAX**" through the drill-holes in the inspection glass.

### 3.1 Hook lubrication



#### **Caution: Risk of injury!**

Turn off the main switch.

Adjust the hook lubrication only with the sewing machine switched off.  
Make functional test with utmost caution when the sewing machine is running.

#### **Standard checking**

The necessary oil quantity for the correct lubrication of the hook is factory set by the manufacturer. It may be modified, only in exceptional cases.

The required oil quantity depends on the sewing threads to be processed and on the fabric.

A piece of paper - preferably blotting paper - held below the hook has to be slightly sprayed with oil when sewing approx. 1 m of sewing thread and fabric.

#### **Correction**

- Adjust the oil quantity with the regulating screw 1.  
Turn screw counter-clockwise = increase the oil quantity  
Turn screw clockwise = reduce the oil quantity.



#### **ATTENTION!**

The adjusted oil quantity only changes after a several minutes of operation.

## 4. Maintenance



### Caution: Risk of injury!

Turn the main switch off.  
The maintenance may only be carried out with the sewing machine switched off!

The daily or weekly maintenance work (cleaning and oiling) to be carried out by the operators of the sewing machine is described in the operating instructions (part 1). It is only listed in the following table for the sake of completeness.

Maintenance work to be carried out	Operating hours			
	8	40	160	500
<b>Sewing head</b>				
- Remove sewing dust and thread waste .....	x			
- Check the oil level in the oil reservoir for the lubrication of the machine head .....		x		
<b>Sewing motor</b>				
- Clean motor fan grill .....	x			
- Check status and tension of the V-belt .....			x	
<b>Pneumatic system</b>				
- Check water level in the pressure regulator .....		x		
- Clean filter element of the compressed air maintenance unit .....				x
- Check the tightness of the pneumatic system .....				x

GB

Notes: