

Manual, complete
745 - 34 Speedpocket

**Sewing unit for runstitching
of rectangular piped pockets**

[Operating Instructions](#)

1

Installation Instructions

2

Service Instructions

3

Instructions for programming DAC

4



745 - 34 Speedpocket

Manual, complete

Summary

Operating Instructions
Installation Instructions
Service Instructions
Instructions for programming DAC

Interconnection diagram

9870 745131 B
9890 745001 B

Pneumatic circuit plan

9770 745002

Preface and general safety instructions

Part 1: Operating Instructions 745-34 Speedpocket

1.	Description of product	3
1.1	Description of proper use	3
1.2	Brief description	3
1.3	Technical data	4
1.4	Optional equipment	5
2.	Operation	7
2.1	Swinging the folding station aside.	7
2.2	Pushing the covering hood back and removing the fabric sliding sheet	8
2.3	Tilting the machine head up	11
2.4	Needles and threads	12
2.5	Threading in the needle thread	15
2.6	Winding up the hook thread	16
2.7	Changing the bobbins	17
2.8	Thread tension	19
2.9	Stacking control	20
2.10	Corner knife station	21
2.10.1	Swinging the corner knife station out / in	22
2.10.2	Adjusting the corner knives	23
2.11	Reference position - Starting the sewing cycle - Quick stop	24
2.12	Flap and piping projection	25
2.13	Piping strip length	26
2.14	Working method	27
2.14.1	Working method (production of trousers)	28
2.14.2	Sewing with flap	31
2.14.2.1	Sewing without light-barrier	31
2.14.2.2	Sewing with light-barrier	33
3.	Maintenance	34
3.1	Cleaning	34
3.2	Weekly lubrication	36

1. Description of product

1.1 Description of proper use

The 745-34 Speedpocket is a sewing unit determined to sew light to medium-weight material, i.e. fabrics made of textile fibres or leather. These materials are used in the clothing industry.

Generally only dry material should be processed with this machine. It should not contain any hard objects.

In general, the seam is made with core thread, Polyester fibre or cotton threads.

The dimensions for needle and hook threads can be taken from the table in chapter 2.4.

Before using any other threads it is necessary to estimate the consequent risks and to take corresponding safety measures, if required.

This sewing unit must be installed and operated in dry and well-kept rooms only. If it is operated in other rooms, which are not dry and well-kept, further measures, which are to be agreed upon, can become necessary (see EN 60204-31:1999).

We, as a manufacturer of industrial sewing machines, take it for granted that at least semi-skilled operators will be working on our products so that we can assume that all usual operations and, where applicable, their risks are known to them.

1.2 Brief description

The **Dürkopp-Adler 745-34S** is a sewing unit for runstitching of rectangular piped pockets.

The piping strips and additional parts are fed manually. Pocket length 20-200 mm (with flap 180 mm max.).

Machine head

- Twin needle lockstitch execution
- Large vertical hooks
- Externally driven center knife
- Thread trimming device for needle and hook threads
- Thread monitor for the needle threads
- DC direct sewing drive

Step motors for the material feed

New generation of control "DAC III" (DÜRKOPP ADLER Control)

The comprehensive testing and monitoring system **MULTITEST** is integrated in the DAC III.

A microcomputer assumes the control tasks, monitors the sewing cycle and indicates faulty operation and malfunctions on the display.

Optional equipment

See chapter 1.4 (Optional equipment of class 745-34S).

Sewing equipment and folders

Information about sewing equipment and folders for the various fields of application can be taken from the Equipment Sheets of class 745-34.

Please address your enquiries to the **DÜRKOPP ADLER**-sales offices.

1.3 Technical data

Machine head:	Class 0246 992003
Needle system:	2134-85
Needle distance:	10, 12 mm
Needle size:	Nm 80 to Nm 110
Threads:	see table chapter 2.4
Stitch type:	Twin needle lockstitch
Speed:	min. 2000 r/ min max. 3000 r/ min
Stitch length:	min. 2.0 to 3.0 mm
Number of stitches condensed stitches:	1 - 10 stitches
Number of stitches bartack stitch:	0 - 5 stitches
Number of stitches condensed stitches / bartack:	0.5 - 3.0 mm
Pocket length:	max. 200 mm
Operating pressure:	6 bar
Air consumption:	approx. 6 NL per work cycle
Rated voltage:	1 x 230 V (50/60 Hz)
Dimensions:	1540 x 1120 x 1200 mm (L x W x H)
Working height:	790...980 mm (upper edge of table top)
Weight:	240 kg
Rated noise level:	LC = 81 dB (A) Workstation-specific emission value According to DIN 45635-48-B-1 Stitch length: 2,5 mm Seam length: 180 mm Speed: 2750 rpm Material: double fabric 240g/m ² Measuring point according to DIN 4895 Part 1 X = 600 mm Y = 0 mm Z = 300 mm

1.4 Optional equipment

Order No.	Optional equipment
0792 011161	Mounting kit K Flap clamp, left, for jackets
0792 011162	Mounting kit K Flap clamp, right, for trousers
0745 427514	Pincer stacker Universal stacking device (pincer stacker) for stacking to the side
0797 003031	Pressure line Connection hose to the pneumatic supply line with corresponding couplings



1

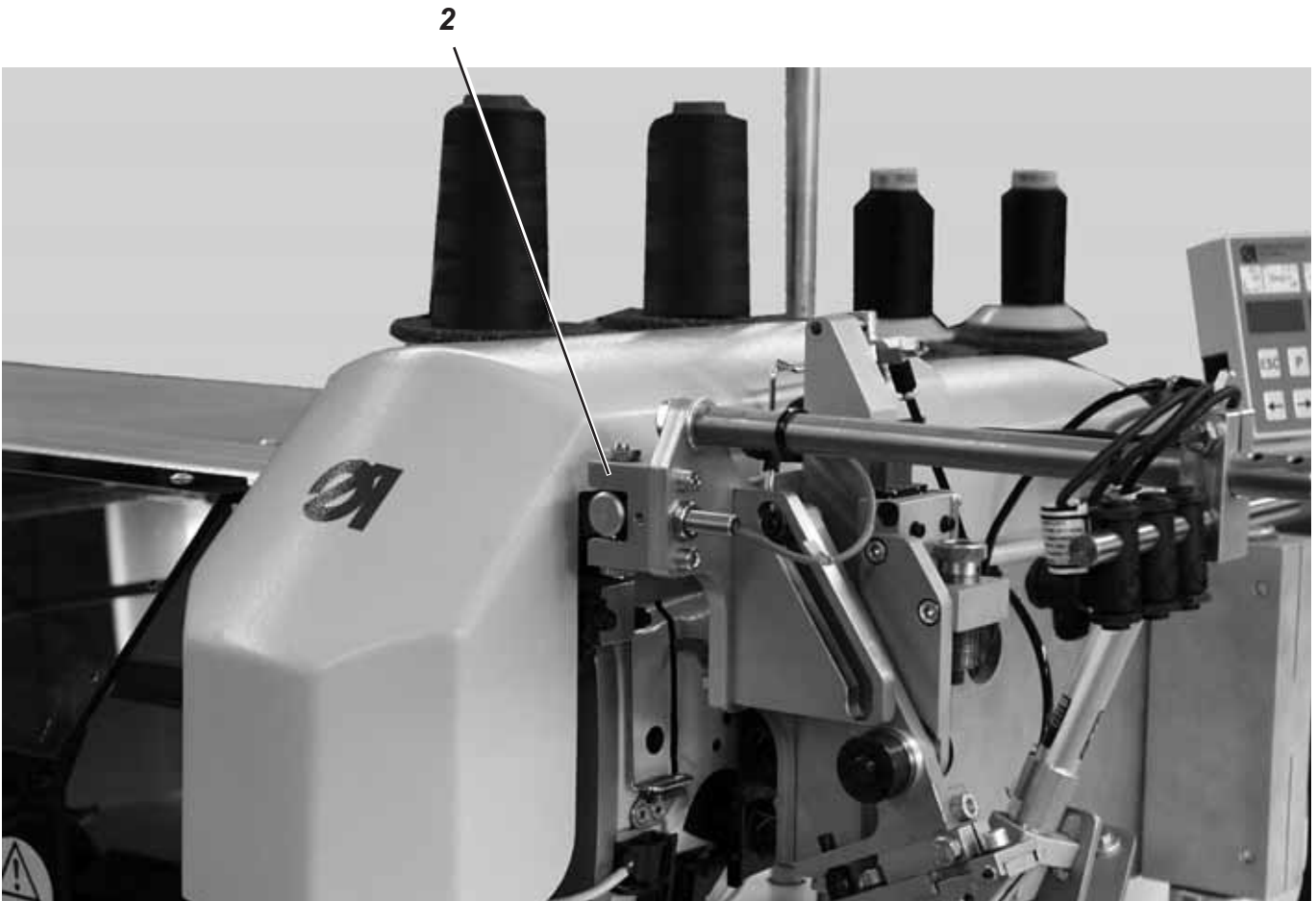

2

2. Operation

2.1 Swinging the folding station aside

For work at the sewing point (threading in the needle threads, needle change etc.) the whole folding station with folder and light-barriers can be swung out to the right side.

- Swing the complete folding station 1 with folder to the right.

Hint:

With the sewing unit turned on, a safety message appears on the screen of the control panel.

E r r	9002
-------	------

Folding station swung out

- The sewing point is freely accessible.

Swinging the folding station back

- Swing the folding station back.



ATTENTION !

After the folding station has been swung back, it must lock in catch 2.

2.2 Pushing the covering hood back and removing the fabric sliding sheet



Caution: Danger of injury!

Switch the main switch off .
Push the covering hood back and remove the fabric sliding sheets only with the sewing unit switched off.

- Switch the main switch off.



2

1



3

Pushing the covering hood back

- Loosen screw 1 of covering hood 2.
- Push the covering hood 2 to the left.



ATTENTION!

Push the covering hood 2 to the left only so far that the cable 3 of the light-barrier is not damaged.

- Push the covering hood 2 back to the right again.
- Secure the covering hood 2 against displacement with the screw 1.

Note!

With the covering hood pushed back, a safety message appears on the screen of the control panel.

E r r	9004
-------	------

Covering hood not pushed back.

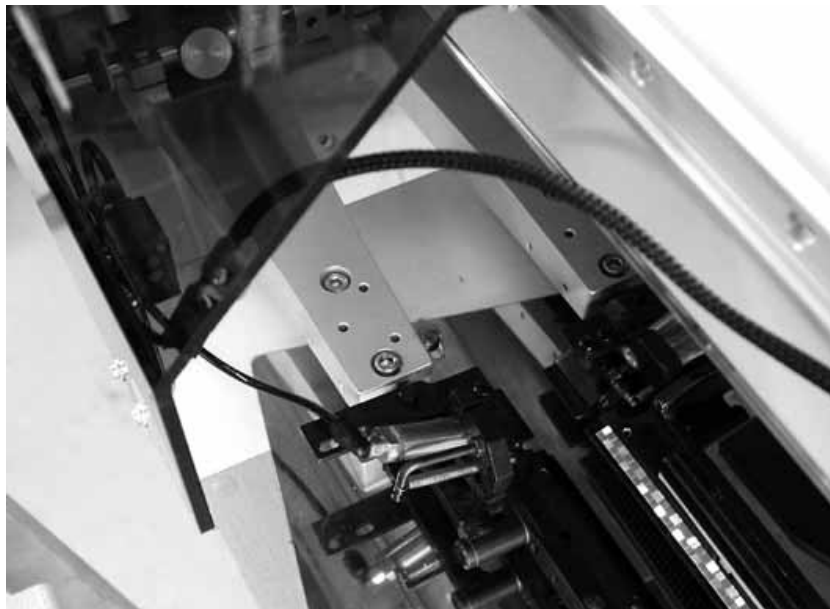
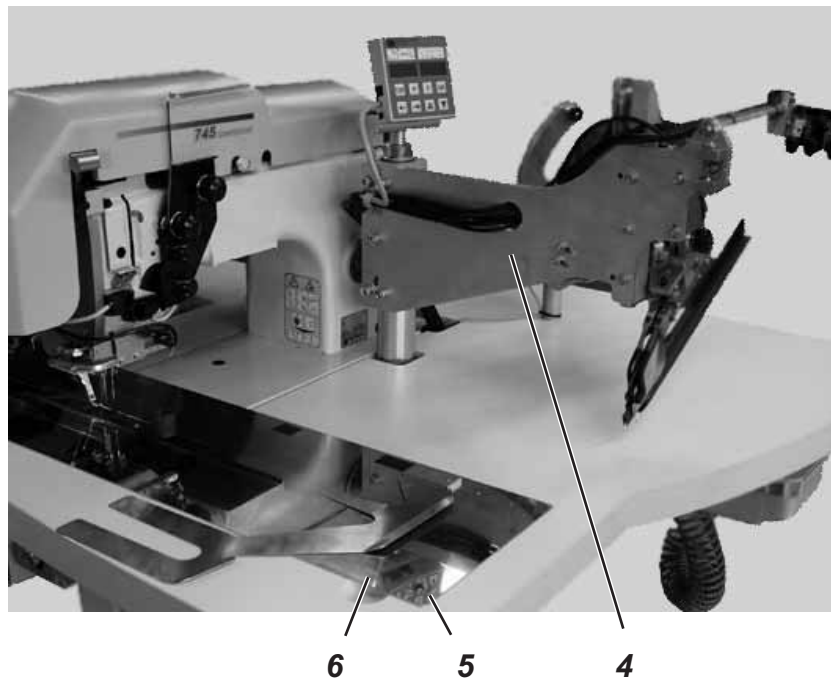

Removing the fabric sliding sheet

For changing the hook thread bobbins:

- Swing the folding station 4 out by 90°.
- Lift the fabric sliding sheet 6 in the area of pin 5 and swivel it away to the left.

For complete removal (for maintenance and setting work):

- Remove the fabric sliding sheet.

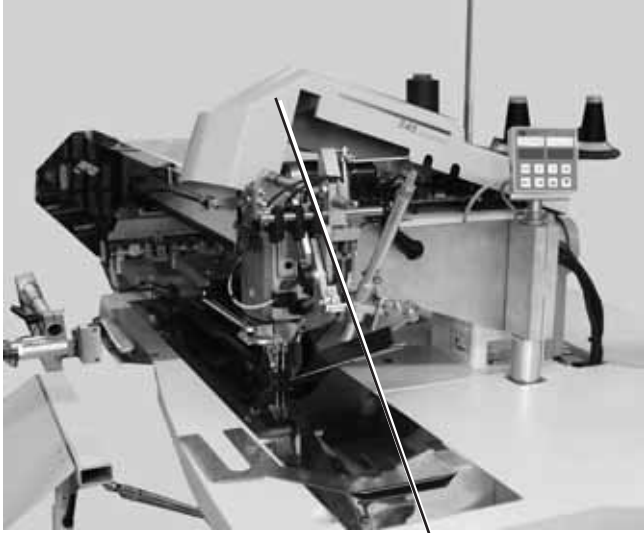

1

1

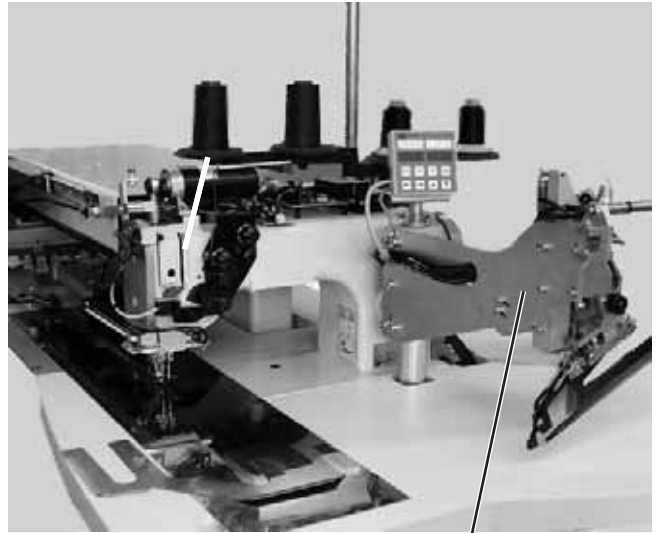

2

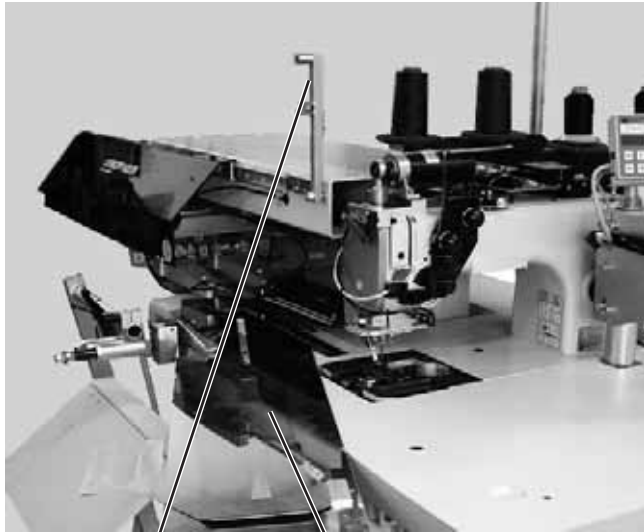

4

3



5

2.3 Tilting the machine head up

For maintenance work the machine head can be tilted up.
For this purpose the transport carriage must be in its rear position.



Caution: Danger of injury!

Switch the main switch off.
Tilt the machine head up only with the main switch turned off.

Tilting the machine head up

- Remove the covering hood 1.
For this purpose lift the covering hood at the front so that the locking is released. Lift the covering hood off carefully.
- Swing the folding station 2 out by 90°.
- Swivel the locking lever 4 up.
- Lift the fabric sliding sheet 3 at the front and swivel it to the left.
- Lift the machine head in the area of the head cover and tilt it up carefully until catch 5 locks. The latch snaps in additionally.
The space under the machine table is accessible for cleaning work.

Swinging the machine head back

- Lift catch 5.
- Swing the machine head back carefully.



Caution: Danger of injury!

Hold the machine head tight until it is completely at rest when lowered.
Danger of squashing your fingers between machine head and table top.

- Insert the fabric sliding sheet.
- Swivel the locking lever 4 down.
- Tilt the folding station 2 back and insert it.
- Put the covering hood 1 on again.

2.4 Needles and Threads

Needle system:	2134-85
Recommended needle size:	Nm 90 for thin material Nm 100 for medium-weight material Nm 110 for heavy-weight material

High sewing security and good sewability are achieved with the following core threads:

- Two-ply Polyester Continuous Polyester core-spun (e.g. Epic Poly-Poly, Rasant x, Saba C, ...)
- Two-ply Polyester Continuous Cotton core-spun (e.g. Frikka, Koban, Rasant, ...)

In case these threads are not available, the Polyester fibre or cotton threads listed in the table can also be sewn.

Often two-ply core threads are offered by the thread manufacturers with the same designation as three-ply Polyester fibre threads (3cyl.-spun). This causes uncertainty with regard to twisting and thread thickness.

When in doubt unravel the thread and check if it is twisted 2- or 3-ply. The label no. 120 on the thread reel of a core thread corresponds e.g. to the thread size Nm 80/2 (see table values in brackets).

In case of monofilament threads it is possible to use needle threads and hook threads of the same size. The best results are achieved with soft and elastic threads (software) of the thread size 130 Denier.

Recommended thread sizes:

Needle size Nm	Core thread		Core thread	
	Needle thread Polyester continuous Label No.	Hook thread Polyester core-spun Label No.	Needle thread Polyester continuous Label No.	Hook thread Cotton core-spun Label No.
90	120 (Nm 80/2)	120 (Nm 80/2)	120 (Nm 80/2)	120 (Nm 80/2)
100	100 (Nm 65/2)	100 (Nm 65/2)	100 (Nm 65/2)	100 (Nm 65/2)
110	75 (Nm 50/2)	75 (Nm 50/2)	75 (Nm 50/2)	75 (Nm 50/2)

Needle size Nm	Polyester fibre thread (3cyl.-spun)		Cotton thread	
	Needle thread	Hook thread	Needle thread	Hook thread
90	Nm 80/3-120/3	Nm 80/3-120/3	Ne _B 50/3-70/3	Ne _B 50/3-70/3
100	Nm 70/3-100/3	Nm 70/3-100/3	Ne _B 40/3-60/3	Ne _B 40/3-60/3
110	Nm 50/3-80/3	Nm 50/3-80/3	Ne _B 40/4-60/4	Ne _B 40/4-60/4

Changing the needles

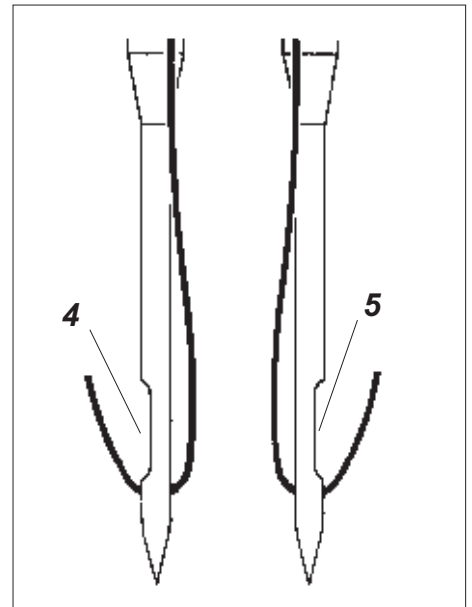
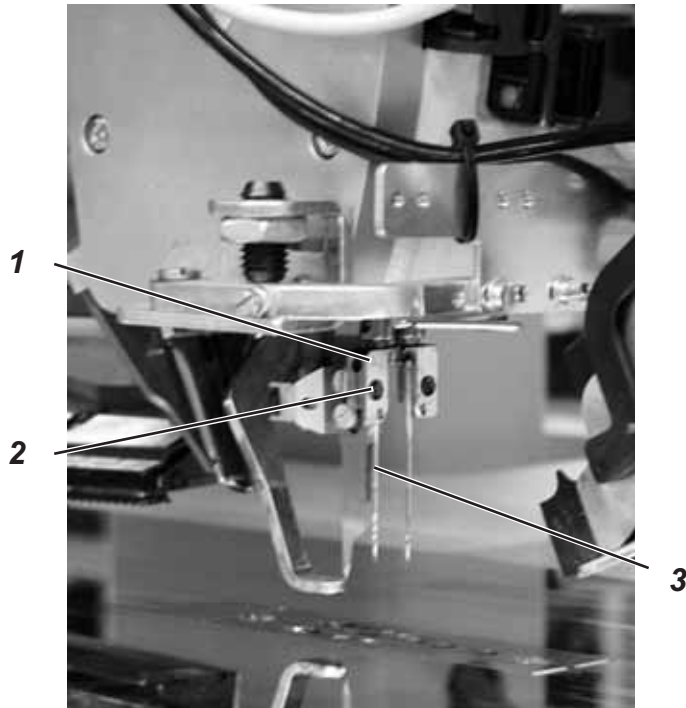

Caution: Danger of injury!

Switch the main switch off.
Change the needles only with the main switch turned off.

Danger of cutting your fingers!

Do not reach into the area of the center knife 3 when changing the needles.

- Swing the folding station aside (see chapter 2.1)
The needles are freely accessible.
 - Loosen screw 2 and remove the needle from the needle holder 1.
 - Insert the new needle in the drill-hole of needle holder 1 as far as it will go.
- ATTENTION!**
Seen from the operator's side, the hollow groove 4 of the left needle must point to the left and the hollow groove 5 of the right needle to the right (see sketch).
- Tighten screw 2.



ATTENTION!

After changing over to another needle size the needle protection on the hook has to be readjusted (see Service Instructions).

Hint:

The standard needle size of class 745-34 is Nm 100 .

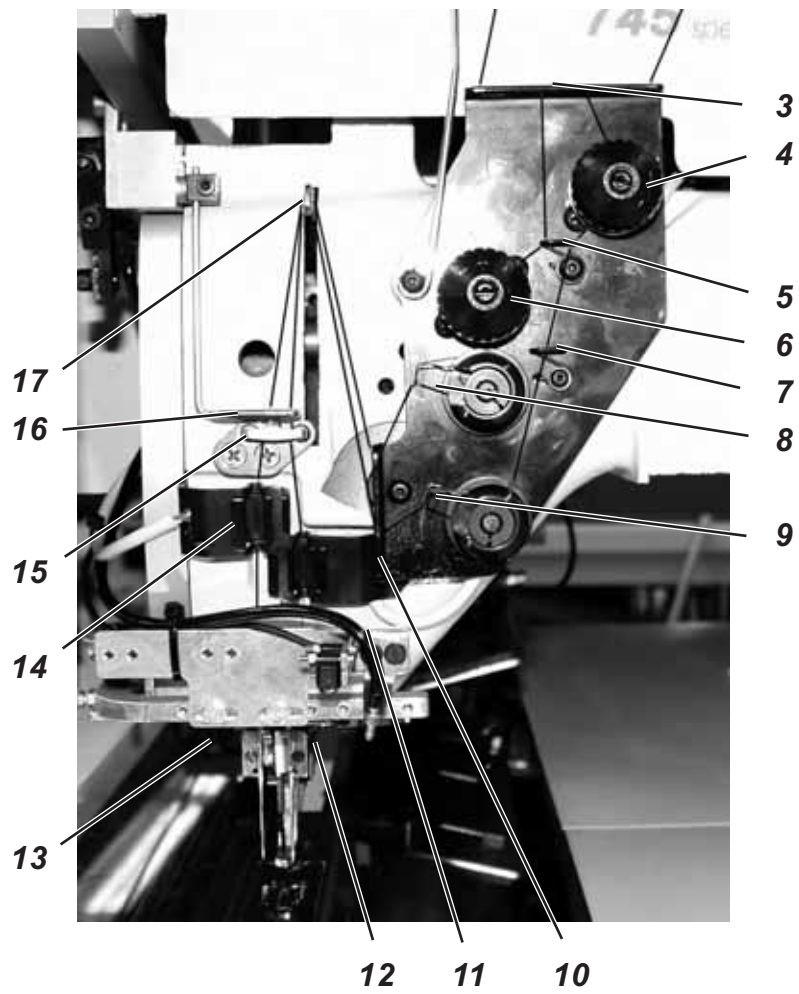
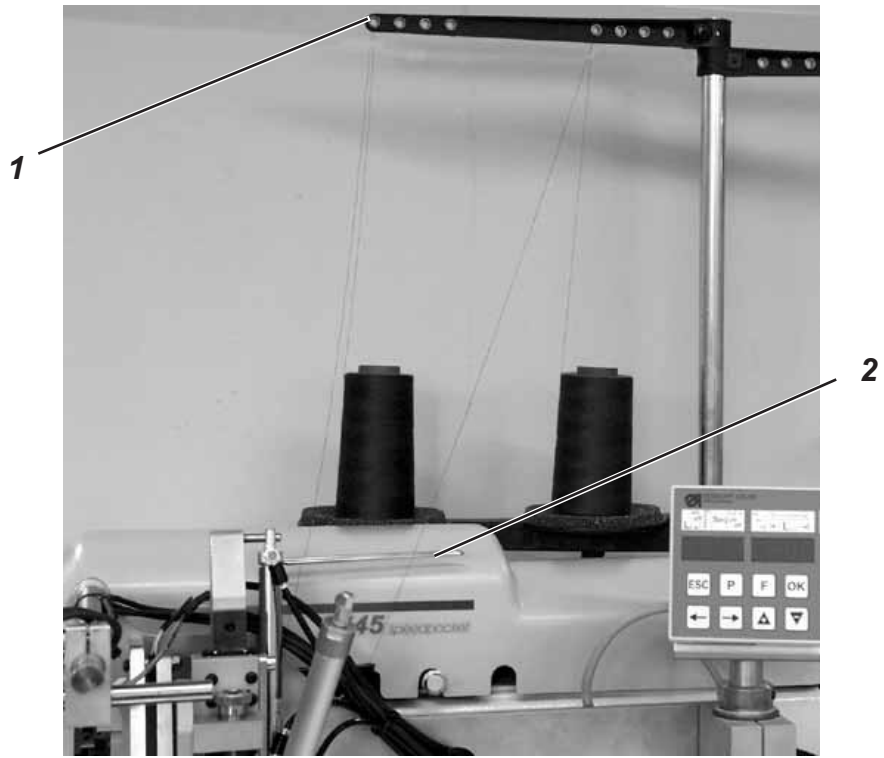

2.5 Threading in the needle thread



Caution: Danger of injury!

Switch the main switch off.

Thread needle threads in only with the sewing unit switched off.

The threading-in of the needle threads is done in ascending numerical order, as shown in the illustrations opposite:

- Swing the folding station aside

Left needle

- Put the thread reel on the thread reel holder.
- Thread the thread from the thread reel through the drill-hole 1 of the thread reel holder.
- Guide the thread through the guide 2.
- Guide the thread through the drill-hole in support plate 3.
- Guide the thread through the guide 5.
- Guide the thread through the tensions discs of needle thread tension 6.
- Guide the thread through the thread controller spring 8.
- Guide the thread through the drill-hole in support plate 10.
- Thread the thread through the drill-hole in thread lever 17.
- Guide the thread downward through the thread puller 16.
- Thread the thread through the guide 15, through the needle thread monitor 14 and through the thread guide 13 (not visible).
- Thread the thread through the guide 12 (not visible), through the drill-hole in the needle holder and through the eye of the needle.

Right needle

- Put the thread reel on the thread reel holder
- Thread the thread from the thread reel through the drill-hole 1 of the thread reel holder.
- Guide the thread through the guide 2.
- Guide the thread through the drill-hole in the support plate 3.
- Thread the thread through the tension disc of the needle thread tension 4.
- Thread the thread through the guides 5 and 7.
- Guide the thread through the thread controller spring 9.
- Guide the thread through the drill-hole in support plate 10.
- Thread the thread through the drill-hole in the thread lever 17.
- Thread the thread downward through the thread puller 16, through the guide 15, through the needle thread monitor 11 and through the thread guide 13.
- Thread the thread through the guide 12 (not visible), through the drill-hole in the needle holder and through the eye of the needle.
- Clamp the threads in the needle thread catcher and cut them off.

2.6 Winding up the hook thread



1



4

3

2



The external bobbin winder allows to wind up the hook threads independent of sewing.

- Remove remaining thread from the winder hubs before winding-up.
- Put the thread reel on the thread reel holder.
- Thread the thread through the drill-hole 1 of the unwinding arm (see picture on the left).
- Guide the thread through the guide 4.
- Guide the thread through the bobbin thread tension 2.
- Prewind the thread to the right in the front and hind reserve grooves of the bobbin hub.
The full reserve grooves guarantee a secure winding even with monofilament threads.
- Press the bobbin retainer 3 against the bobbin hub.
The winder starts.
After reaching the set bobbin filling quantity the winder stops automatically.
See the Service Instructions for setting the bobbin filling quantity.

2.7 Changing the bobbins

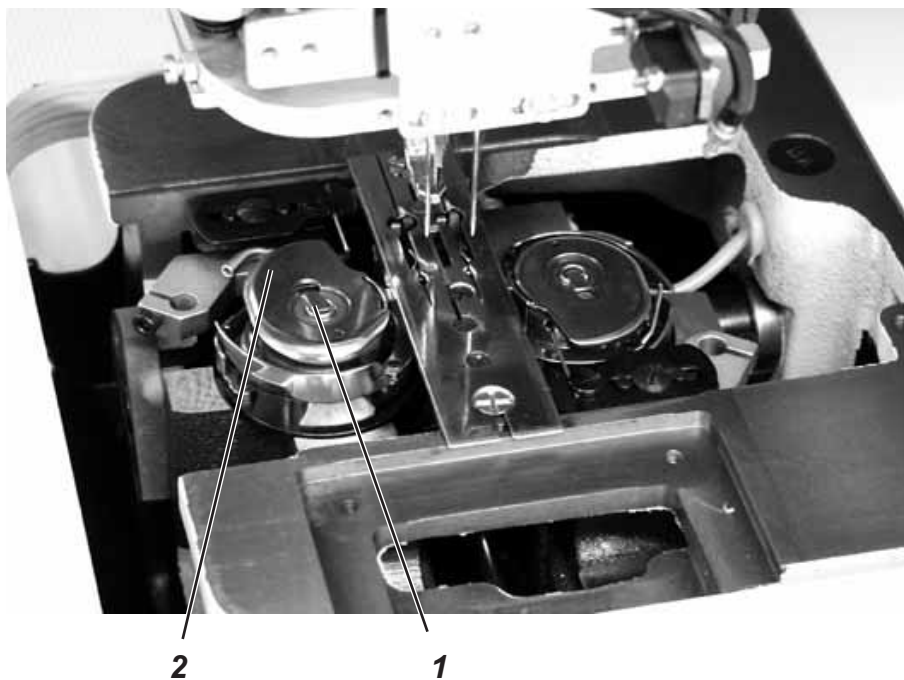

ATTENTION!

Switch the main switch off before changing the bobbins.

After a certain number of seams the hook thread stock on the bobbin is used up.

With the remaining thread monitor switched on the message Err 9602 appears on the screen.

After the corner incision the workpiece is moved out or stacked respectively.

The sewing unit can only be restarted after the bobbin change. (See chapter "Setting the number of stitches").

Removing the empty bobbin

- Switch the main switch off.
- If the transport carriage is in front position, push it to the rear by hand.
- Swing the folding station aside.
- Lift the fabric sliding sheet and swivel it to the left (see chapter 2.2).
- Lift the upper part of the bobbin case in the area 2. The bobbin case retainer 1 is lifted simultaneously.
- Remove the upper part of the bobbin case together with the empty bobbin.
- Remove the empty bobbin from the upper part of the bobbin case.

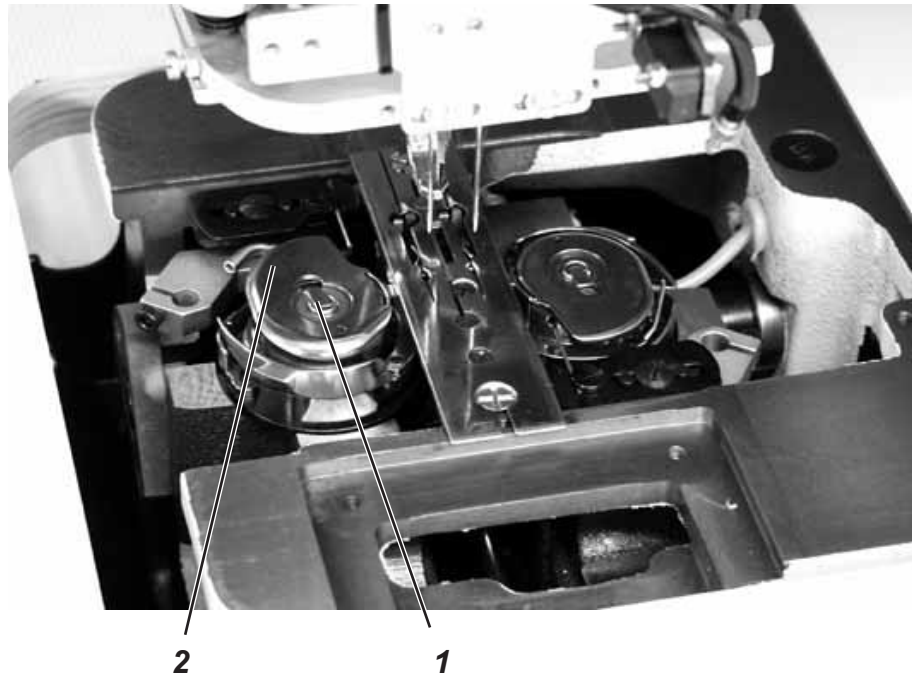

Inserting a full bobbin

- Insert a full bobbin in the upper part of the bobbin case 2.
- Pull the thread through slit 5 under tension spring 6.
- Pull a thread length of approx. 4 cm out of the upper part of the bobbin case.
When the thread is being pulled off, the bobbin must turn in the direction of the arrow (in the opposite direction to the hook rotation).
- Insert the upper part of the bobbin case 2 with the full bobbin in the lower part of the bobbin case.
- Close the bobbin case retainer 1.
- Put the fabric sliding sheet on again.
- Switch the main switch on.
- Start a new sewing cycle.
The stitch counting has been reset to the old value. (see Programming Instructions "Adjusting programs)

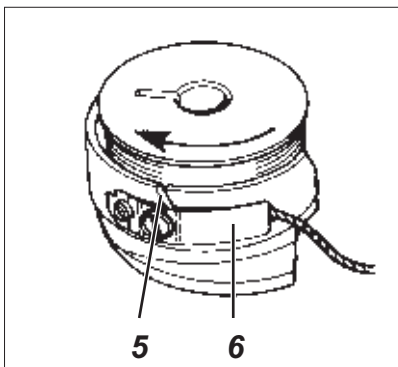

2.8 Thread tension

The interlacing of the threads must lie in the middle of the workpiece. Thick and hard material requires a tighter thread tension than thin and soft material. In case of thin material a too high thread tension can lead to undesired ruffling and thread breakage.

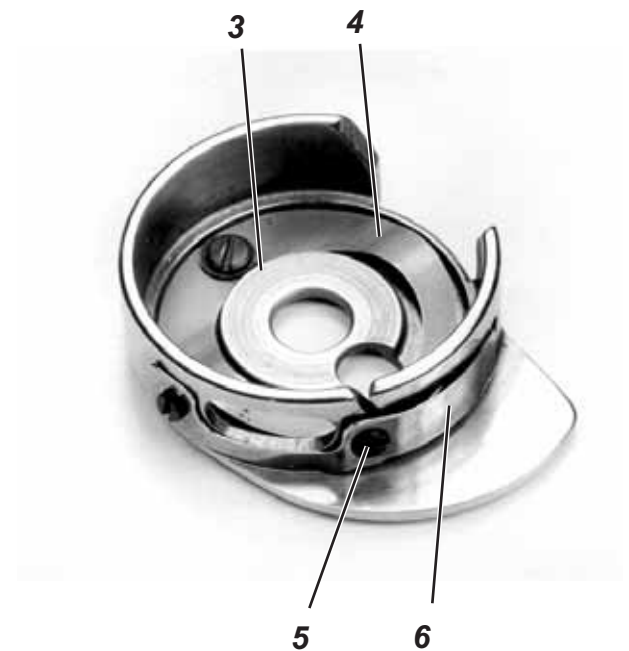
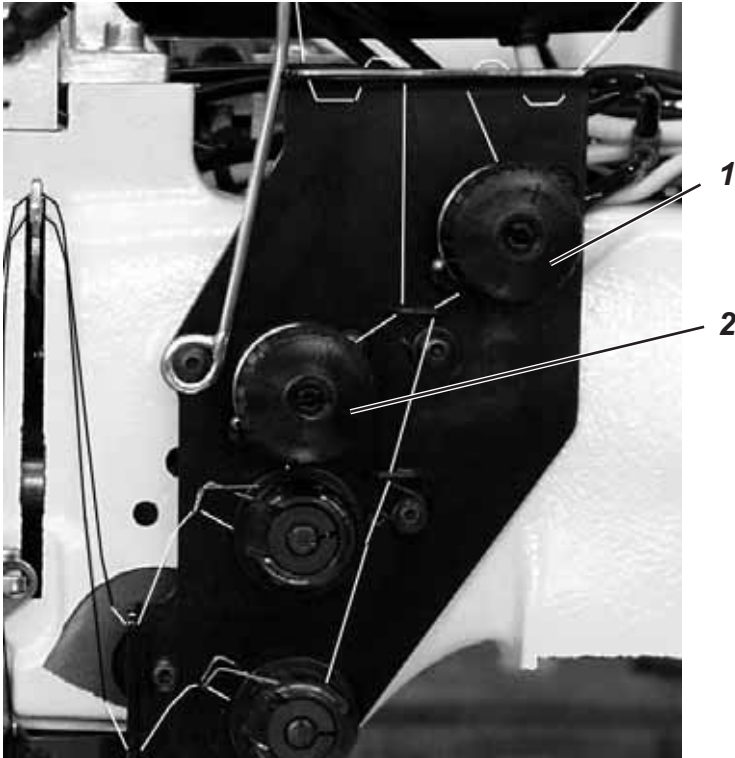

Setting the brake spring 4:

In case of a positioned stop of the machine head the brake spring 4 avoids an after-run of the hook thread bobbin.

- Set the brake spring 4 by alignment.
The brake power is adjusted correctly when the brake spring 4 projects approx. 1 mm above surface 3.
- When setting the tension spring 6 the brake power is to be taken into account.

Setting the tension spring 6:

- First set only a minimum tension of leaf spring 6 at the adjusting screw 5.
Increase the hook thread tension: Turn to the right
Reduce the hook thread tension: Turn to the left
- With the bobbin inserted and the hook thread threaded through the throat plate a uniform and easy pull-off must be assured.

Setting the needle thread tension:

- Adjust the needle thread tension until a uniform stitch pattern is achieved.
- Adjust the tension of the needle threads at knurled nut 1 (right needle thread) and knurled nut 2 (left needle thread).
Increase the needle thread tension: Turn to the right
Reduce the needle thread tension: Turn to the left

2.9 Stacking control

The reflected light-barrier 1 monitors the stacking of the sewn workpiece.
The transport carriage does not run back before the workpiece has been moved out correctly.

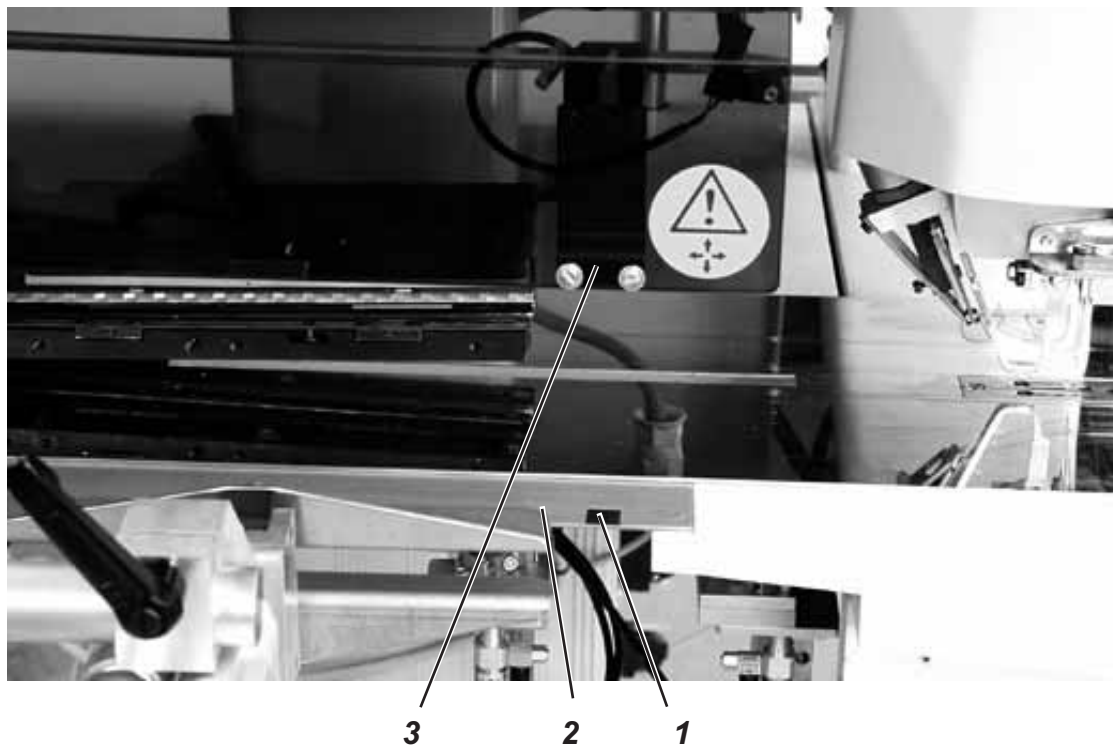

If the workpiece is not moved out correctly, the light beam between the reflected light-barrier 3 and the reflector 1 remains interrupted. A renewed starting is not possible. After stepping on the pedal an error message appears.

If the Teflon foil 2 is worn, it has to be replaced.
The Teflon foil has the following functions:

- Better withdrawal of material
- Light beam interruption when the cover is open



Caution: Danger of injury!

Do not reach into the run area of the transport carriage when removing the workpiece.

In case of sewing programs with automatic carriage return the transport carriage moves to the front after release of the light beam.

- Remove the workpiece out of the light beam.
A new sewing cycle can be started.



ATTENTION !

For a secure function of the stacking control clean the lens of the reflected light-barrier with **asoft** cloth once a day.

2.10 Corner knife station

The 745-34S is equipped with a manual corner knife station.

The setting of the corner knives with regard to the pocket length is done by adjusting the knife block.

The distance of the corner knives to the seam is manually adjustable.

The whole knife block can be tilted out in order to make adjusting and service work possible.



2.10.1 Swinging the corner knife station out / in

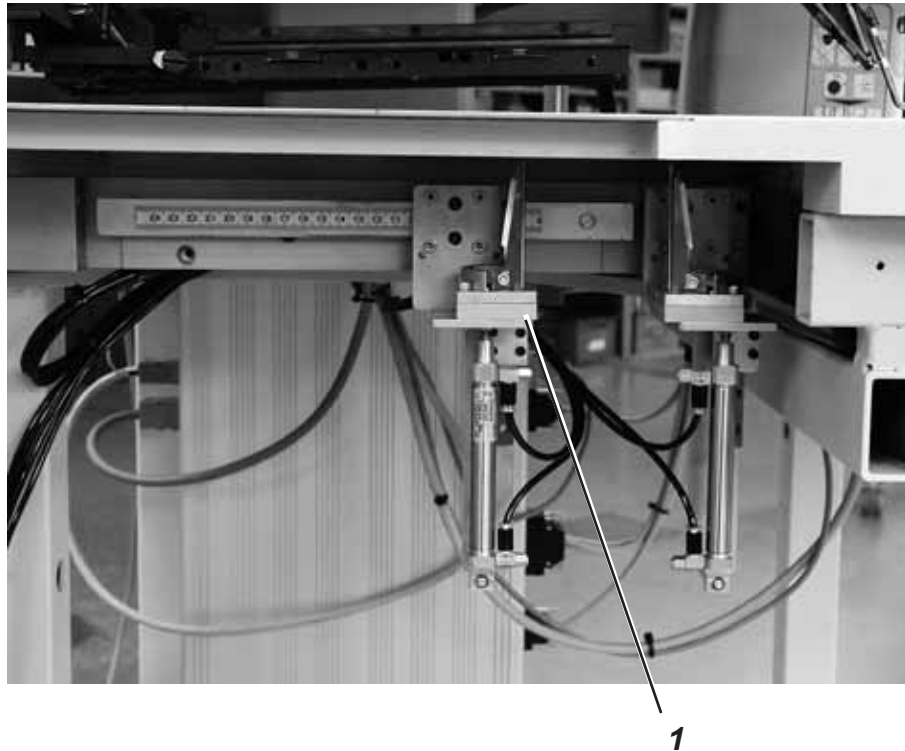

Caution: Danger of injury!

Switch the main switch off.
Swing the corner knife station out only with the sewing unit switched off.

Swinging the corner knife station out

- Swing the corner knife station 1 out to the left.
The knives are accessible for adjusting and service work.

Swinging the corner knife station in

- Swing the corner knife station 1 back under the sewing unit and let it catch.



ATTENTION!

The corner knife station must audibly lock when being pushed in.

Hinweis:

If the corner knife station is swung out with the sewing unit switched on, the following message appears:

Err	9001
-----	------

2.10.2 Adjusting the corner knives

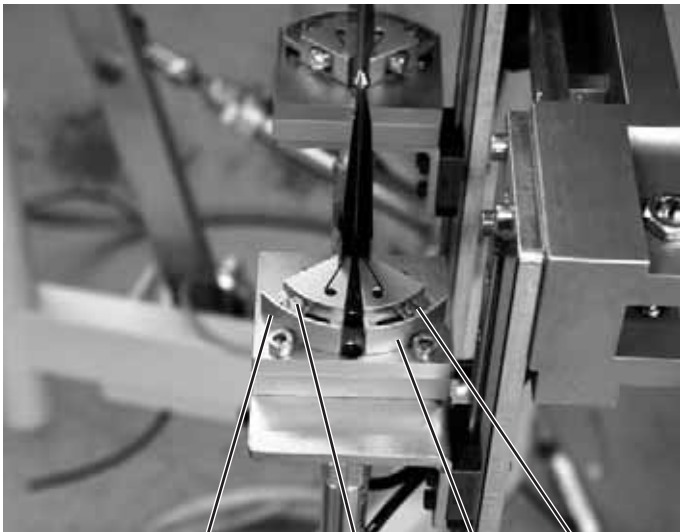

4 3 2 1

6 5



Caution: Danger of injury!

Switch the main switch off.
Adjust the corner knives only with the sewing unit switched off.

- Swing the corner knife station out (see chapter 2.10.1)

Setting the angle of the corner knives

The angle of the corner knife is adjusted by turning the knife blocks 2 and 4.

- Loosen screws 1 and 3.
- Turn the knife blocks 2 and 4 equally.
- Tighten screws 1 and 3.
- Adjust the angle of the other pair of knives correspondingly.

Height of the corner knives

The corner knives are not height-adjustable.
The knives always cut through completely.

- Swing the corner knife station in (see chapter 2.10.1).

Seam beginning

Seam end

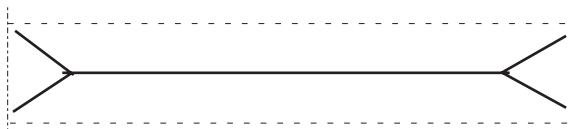

Straight pocket corners
Right and left corner knife
incisions lie parallel

Position of the adjustable knife block

The position of the adjustable knife block corresponds to the seam length L1.

- Loosen clamping lever 5 and set seam length L1 on scale 6.
- Tighten clamping lever 5.

2.11 Reference position - Starting the sewing cycle - Quick stop

Reference position

The reference position is necessary in order to get a defined initial position.

- Switch the main switch on.
The control is initialized.
- The display shows briefly
bF4 (Program version)745(Program number)
- The control checks whether the transport carriage is in its rear end position.
If not, the message “Reference run” is shown on the screen.

r E F	
-------	--

- Step back on the pedal.
The reference run starts.
The transport carriage runs in its rear end position.
- The display changes over to the seam program set before (e.g. L1 -180 mm).

Starting the sewing cycle

- Step forward on the pedal.
By repeated stepping on the left pedal the various steps of the positioning sequence are started sequentially.
- For positioning corrections:
Step back on the pedal.
The last step of the positioning sequence is undone.
A new positioning can be made.
- Step forward on the pedal.
The sewing cycle is started.

Quick stop

The safety system of the 745-34S offers two possibilities for an immediate shut-down of the sewing unit in case of faulty operation, needle breakage, thread breakage etc.:

- Step back on the pedal.
The current step of the positioning sequence or the sewing cycle respectively is stopped immediately.
The following message appears:

E r r	9 6 0 1
-------	---------

- Step back on the pedal again.
The carriage runs out of the feeding area.
- Press key “**RST**” on the control panel.
The current sewing cycle is stopped.

2.12 Flap and piping projection

For the unhindered passage of the workpieces at the folder the maximum projections of piping, flap and material thickness (see sketch) must not be exceeded.
Please take the maximum allowable piping strip widths for the respective sewing equipment (E-No.) from the Equipment Sheets of the 745-34.

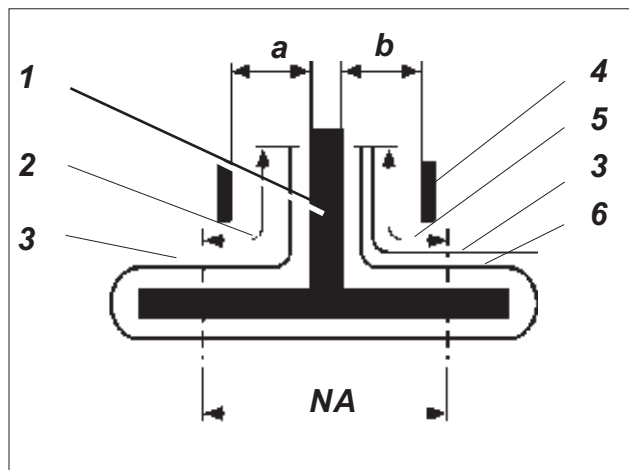

- 1: Folder
- 2: Piping projection, max. 40 mm
- 3: Flap
- 4: Guide plate on the folder
- 5: Flap projection, max. 20 mm
- 6: Piping strip

NA: Seam distance
a, b: Material passage on the folder

Setting the sewing depth of flap 1

Stop guide 3 determines the sewing depth and thus the flap projection.

- Loosen screws 2 and 4.
- Adjust stop guide 3
- Tighten screws 2 and 4.

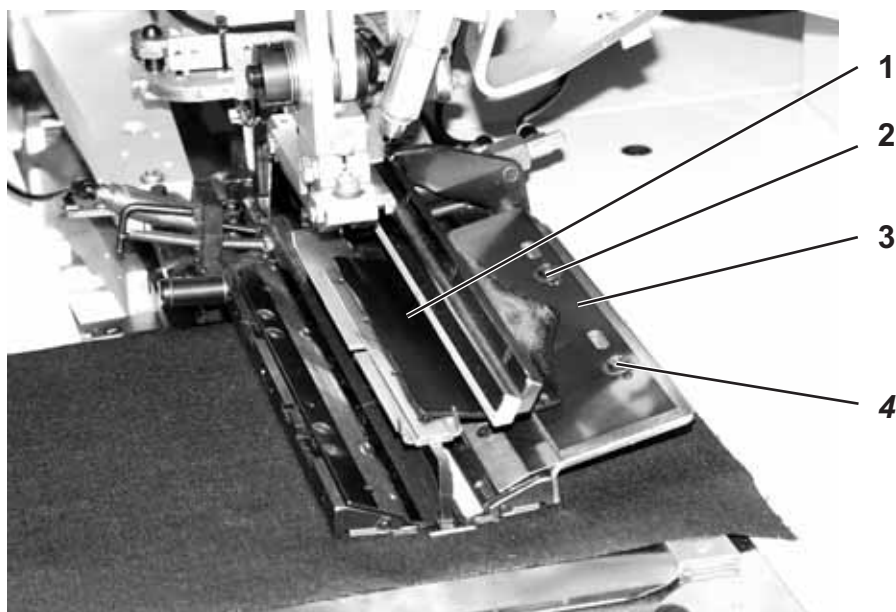

2.13 Piping strip length

The length of the piping strip must be dimensioned in such a way that it projects approx. 20 mm beyond the seam beginning and seam end.
Thus the piping strip length is as follows:

Piping strip length = Sewing length + 2 x 20 mm

2.14 Working method

Working method	Remarks
A	Piped pockets, manual positioning of piping strips, flaps and other additional parts

On the following pages the working method is described.
The description is divided into the following items:

Positioning points

This item indicates which positioning points are used for the various workpieces (e.g. left and right pieces).

Aligning the positioning aids

This section describes the adjustment and alignment of the positioning aids (e.g. positioning marks, marking lamps, stop guides etc.).

Positioning and starting the sewing cycle

Under this item the individual positioning steps are listed with common positioning examples.



Caution: Danger of injury!

Do not reach under the downholder, the feeding clamp and the folder during the positioning process.

2.14.1 Working method (Production of trousers)

Possible processing variants

- Front trousers pockets with pocket bag positioned below
- Hind trousers pockets with or without flap, with pocket bag positioned below

Positioning method

Example: Hind trousers without flap, with pocket bag positioned below

1st step:

- Select the pocket program on the control panel
- Push the pocket bag under pocket bag clamp 1 and position it at the marks 2.
As marks you can use e.g. adhesive tape attached to the fabric sliding sheet.

2nd step:

- Position hind trousers at the “rear positioning point” 4 and at mark 3.
- Touch the pedal.
The hind trousers is firmly clamped in its position by the fabric downholder 5.
- Smooth out the clamped hind trousers in the area of the dart.

3rd step:

- Touch the pedal.
The feeding clamps run forward and lower onto the workpiece. A separate lowering of the clamp halves can be programmed.
For example: the right clamp lowers and the fullness from the trousers is manually smoothed out to the left. Then lower the left clamp.
- Position the piping strip 7 on the feeding clamps flush at the front edges 8.
The alignment of the various piping types on the feeding clamps is described more precisely in the following.
See “Positioning the piping strip”.
- Touch the pedal.
The folder 6 lowers.
- Touch the pedal once again.
The sewing cycle starts.

1st step:

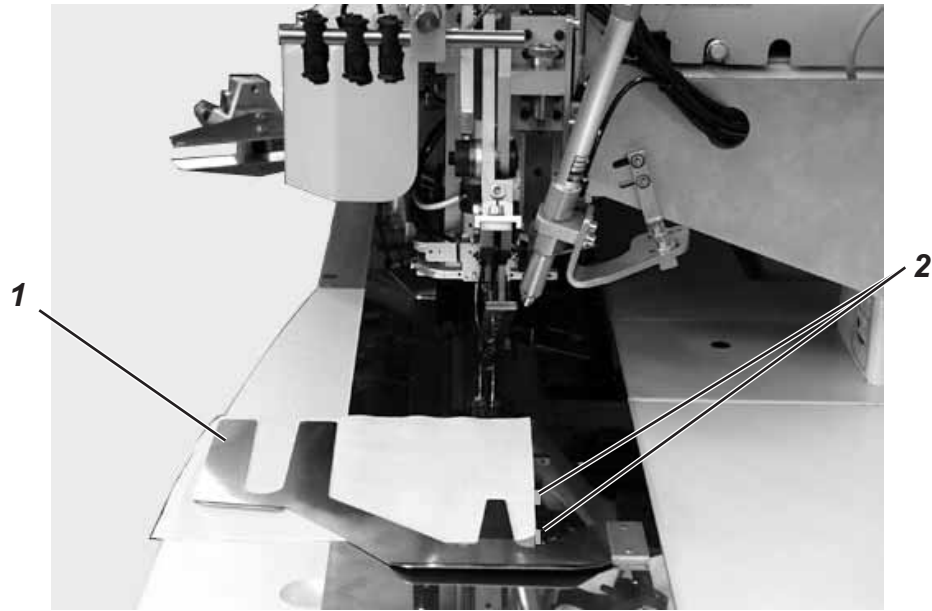

2nd step:



3rd step:

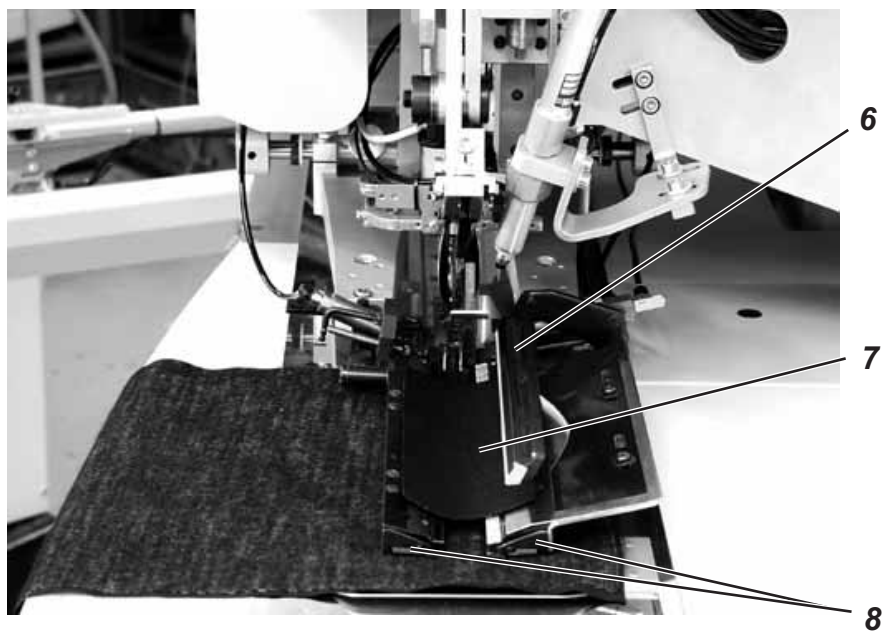

Positioning the piping strip

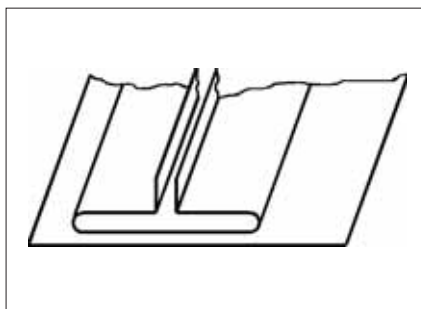

Double piping:

- Position the piping strip centered on the feeding clamps and flush at the front edges.

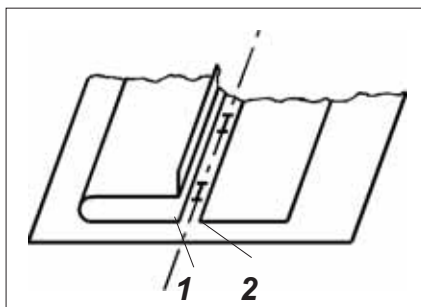

Left single piping with separately positioned right facing:

- Position the piping strip on the left feeding clamp flush with the cutting line.
- Position the facing on the right feeding clamp. This positioning method requires the flap clamp “right” (Order No.0792 011162) available as optional equipment.
- The edges 1 and 2 have to be sufficiently caught by the needle, but must not be cut by the center knife.

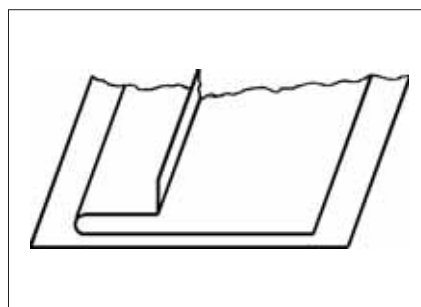

Left single piping with grown-on facing

- Position the piping strip at the stop guide 3 on the left folding sheet.



ATTENTION!

In case of grown-on facings the right folding sheet must not close. Pull off the hose coupling from the right feeding clamp

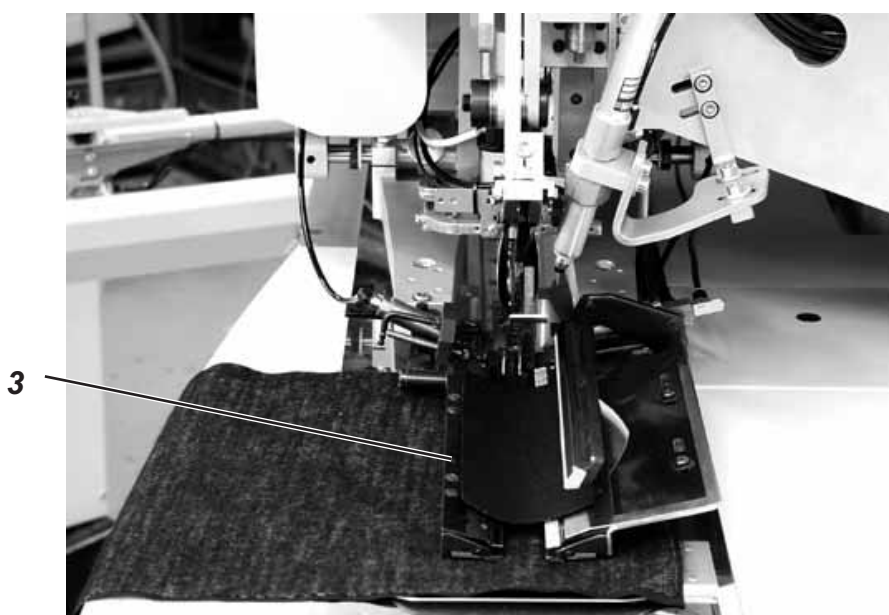

2.14.2 Sewing with flap

For the simultaneous sewing-in of flaps or other additional parts the following optional equipment is required according to the field of application:

Production of trousers: Right flap clamp (Order No. 0792 011162)

Or Left flap clamp (Order No. 0792 011161)

2.14.2.1 Sewing without light-barrier

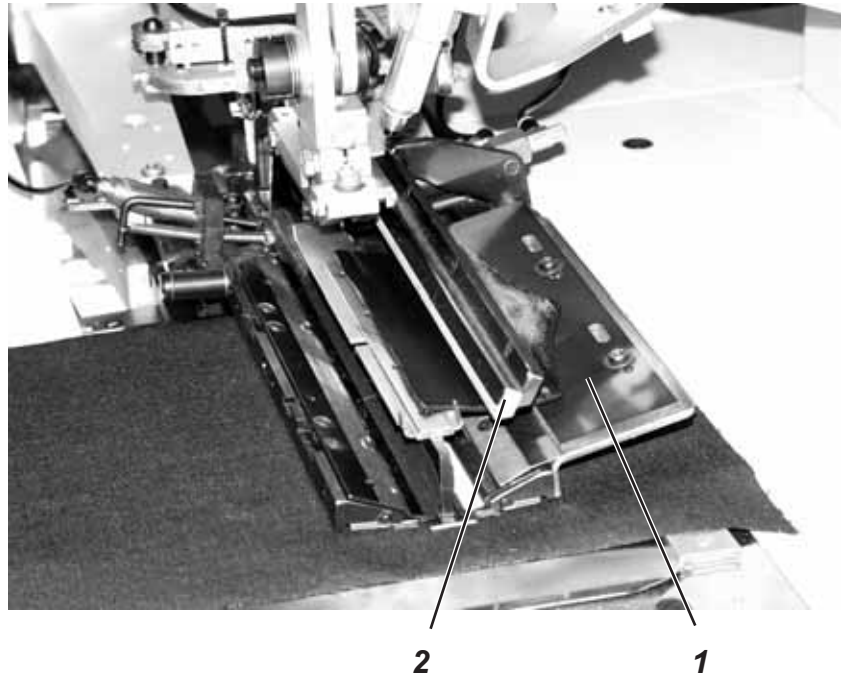

Form stop for the flap

The unmachined part 1 is delivered with the flap clamp 2.
It has to be machined as a form stop corresponding to the flap used.



ATTENTION!

The flap length must correspond to the desired length of the pocket opening.

Sewing with the flap at the right (production of trousers)

- For the production of trousers always position the flap at the "Rear positioning point" (light spot 5).
The "Rear positioning point" applies as a fixed point also for other sewing units (further flap lengths).
- Attach the positioning mark 4 for the hind trousers to the fabric sliding sheet.
- The sketch shows the positioning of a right hind trousers part 3 with flap.
- Position the left hind trousers parts in reflected image.
The position of the flap remains unchanged.

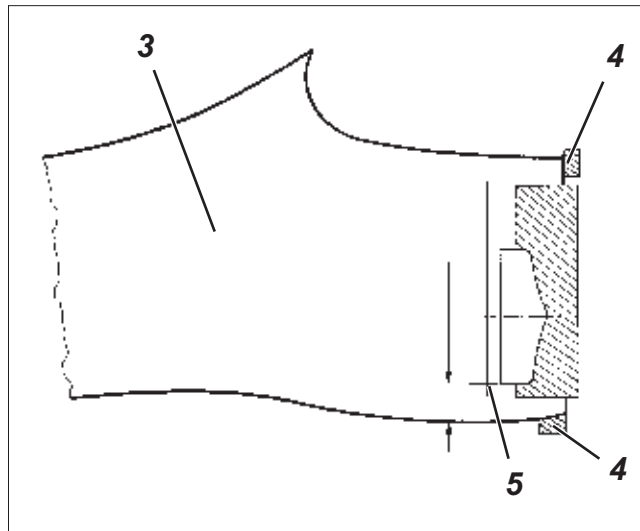

2.14.2.2 Sewing with light-barrier



2

1

When attaching flaps, seam beginning and seam end are recognized by a light-barrier.

Positioning the flap

The positioning marks 1 and 2 on the folder limit the sewing area for the attaching of flaps.

- Always position the flaps **within** the marked area.

If the flap is not positioned correctly, the error message Err 9721 or Err 9722 appears.

Correction of seam beginning and seam end

The correction of the seam beginning (NA) and seam end (NE) when sewing with light-barrier is done in the pocket correction program (see Programming Instructions).

3. Maintenance



Caution: Danger of injury!

Switch the main switch off.

Maintenance work must only be done with the sewing unit switched off.

3.1 Cleaning

A clean sewing unit protects from malfunctions!

Clean and check daily:

- Clean the area around the hooks 1 and 2 with the compressed air pistol.

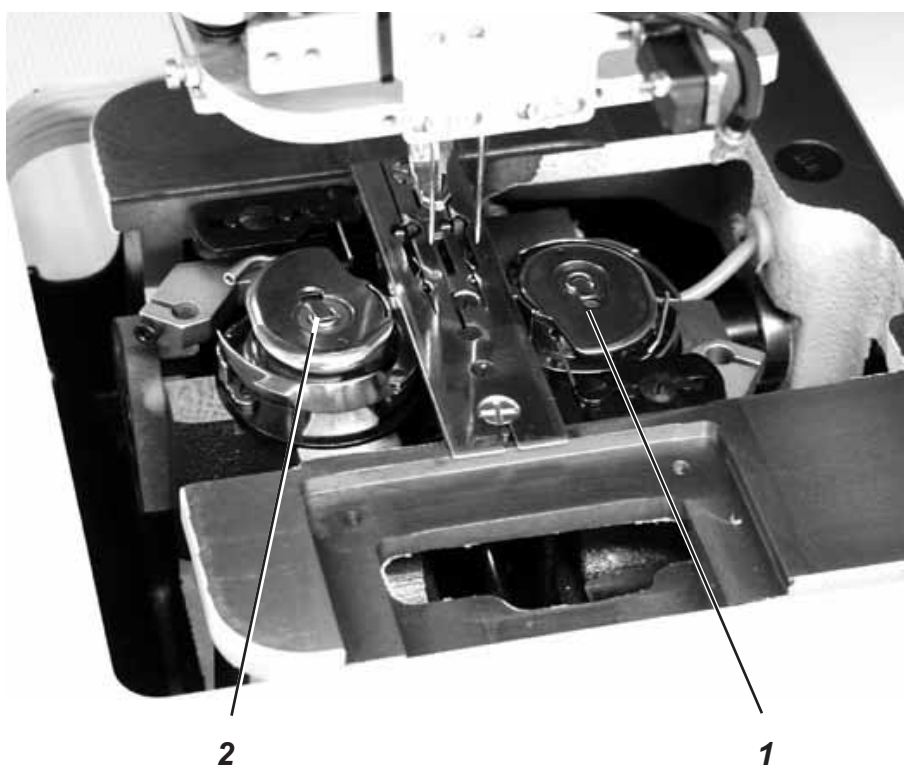

Clean and check daily:

- Check the water level in the pressure regulator.
The water level must not reach the filter element.
After screwing in the drain screw 1 blow the water out of the water separator 2 under pressure.
The filter element 1 separates dirt and condensed water. After a certain operating time wash the dirty filter tray and the filter element with benzine and blow clean with the compressed air pistol.



ATTENTION!

Do not use any solvents for washing out the filter tray and the filter element!
They destroy the filter tray.

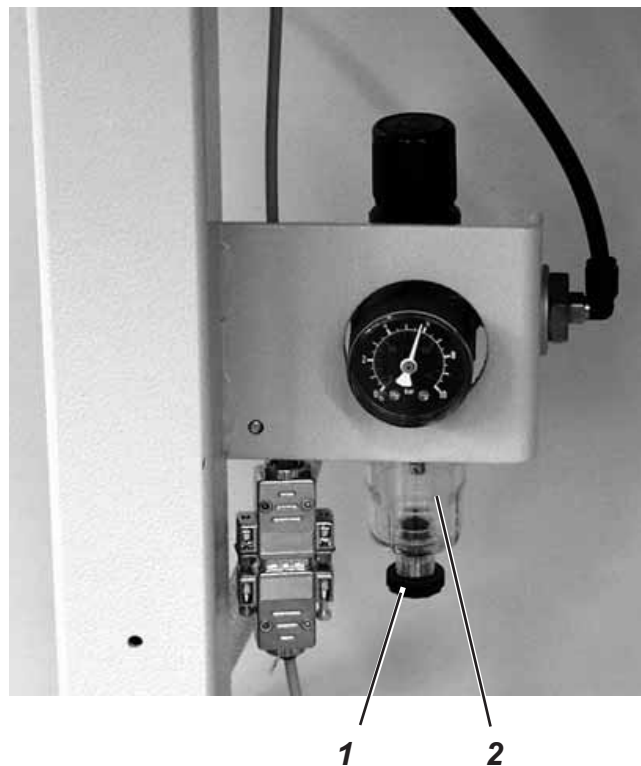

3.2 Weekly lubrication

For lubricating the sewing unit use exclusively the lubricating oil **DA-10**.

DA-10 can be obtained from the sales offices of **DÜRKOPP ADLER AG**.

Check the oil level in the oil reservoir 3 for lubrication of the machine head

- Tilt the machine head up (see chapter 2.3).
- The oil level in the oil reservoir 3 must not drop below the “Min” marking.
- If necessary, fill some oil up to the “Max” marking through the drill-hole in the inspection glass.

Check the oil level in the oil reservoir 5 for lubrication of the hook

- Tilt the machine head up (see chapter 2.3).
- Fill the oil reservoir 5 with oil up to the “Max” marking through the nipple 4 (see sketch).

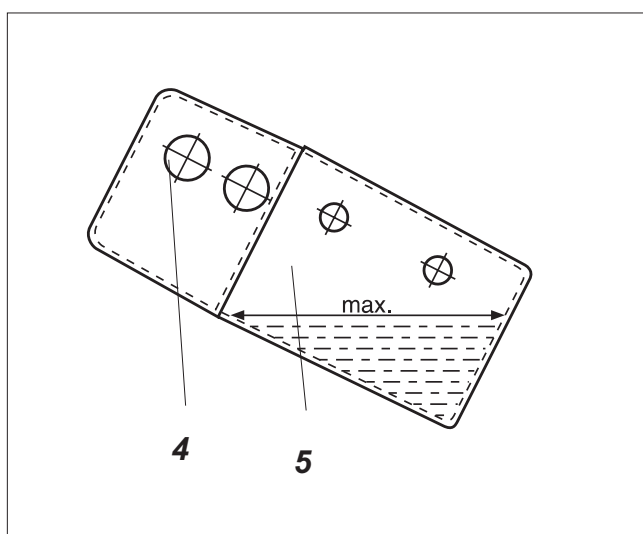
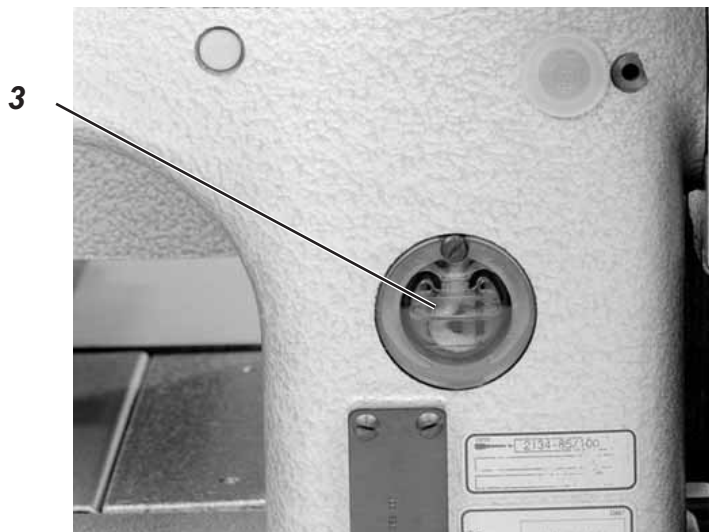

4

5